

Current Electricity

Effects Of Electric Current

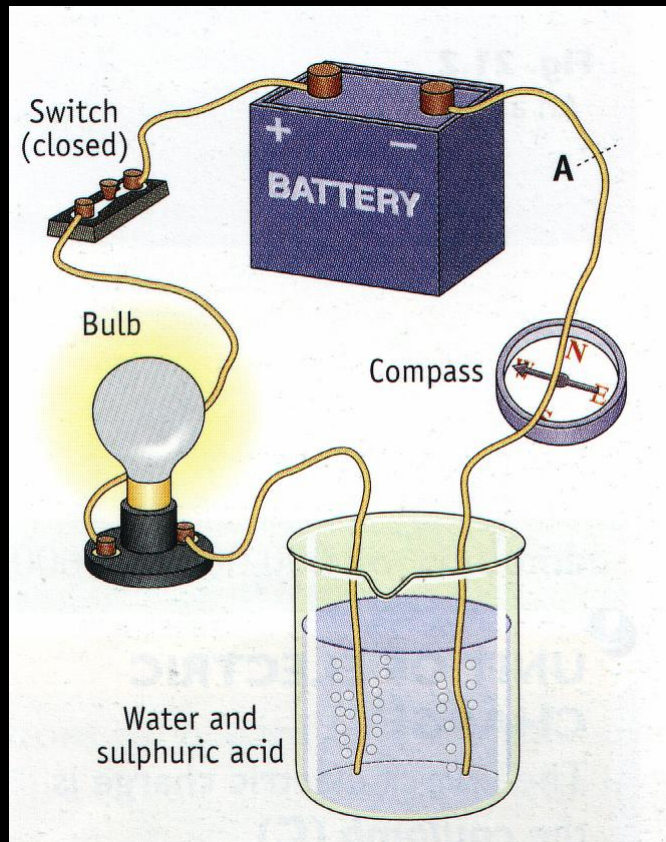

- Heating
- Chemical
- Magnetic

Electric Circuit

Current

**Voltage ...
(Potential Difference)**

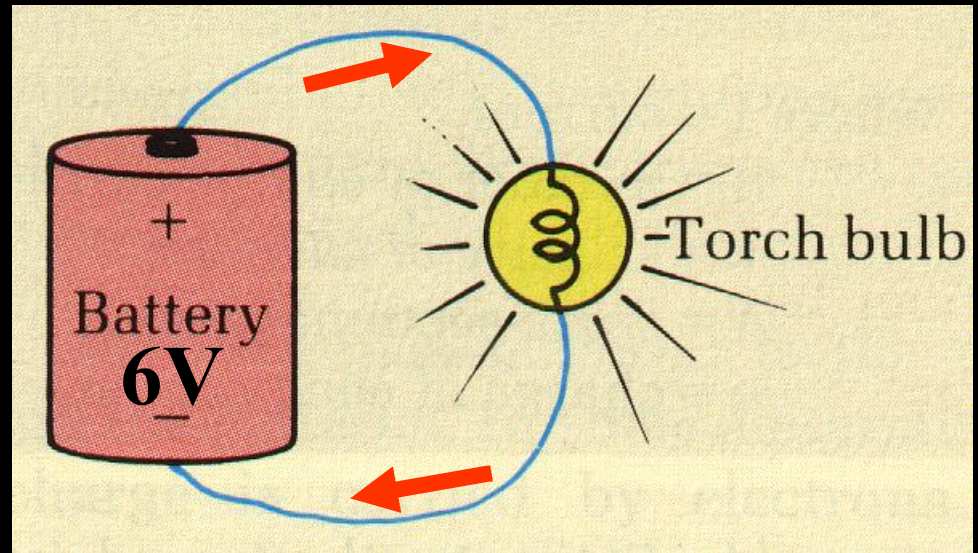

I

Electric Current = ??

A flow of electric charge
A flow of electrons

Potential Difference (*pd*) = ??

Drives ...

Energy to ...

V

+ to -

- to +

Conventional current & Electron flow

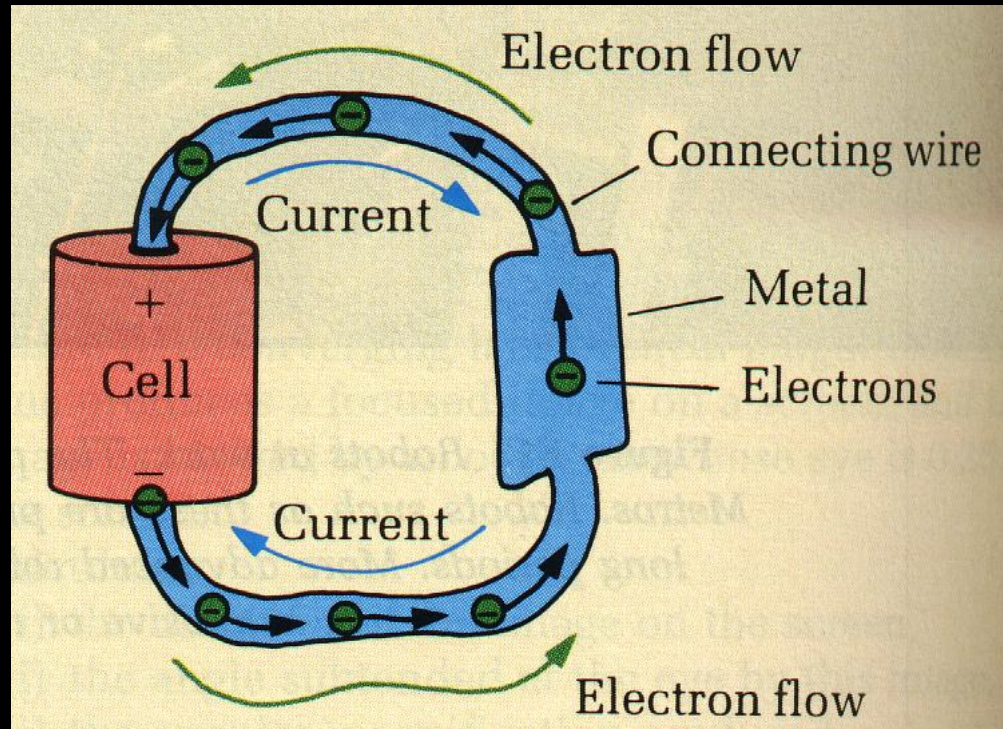

Circuit Components

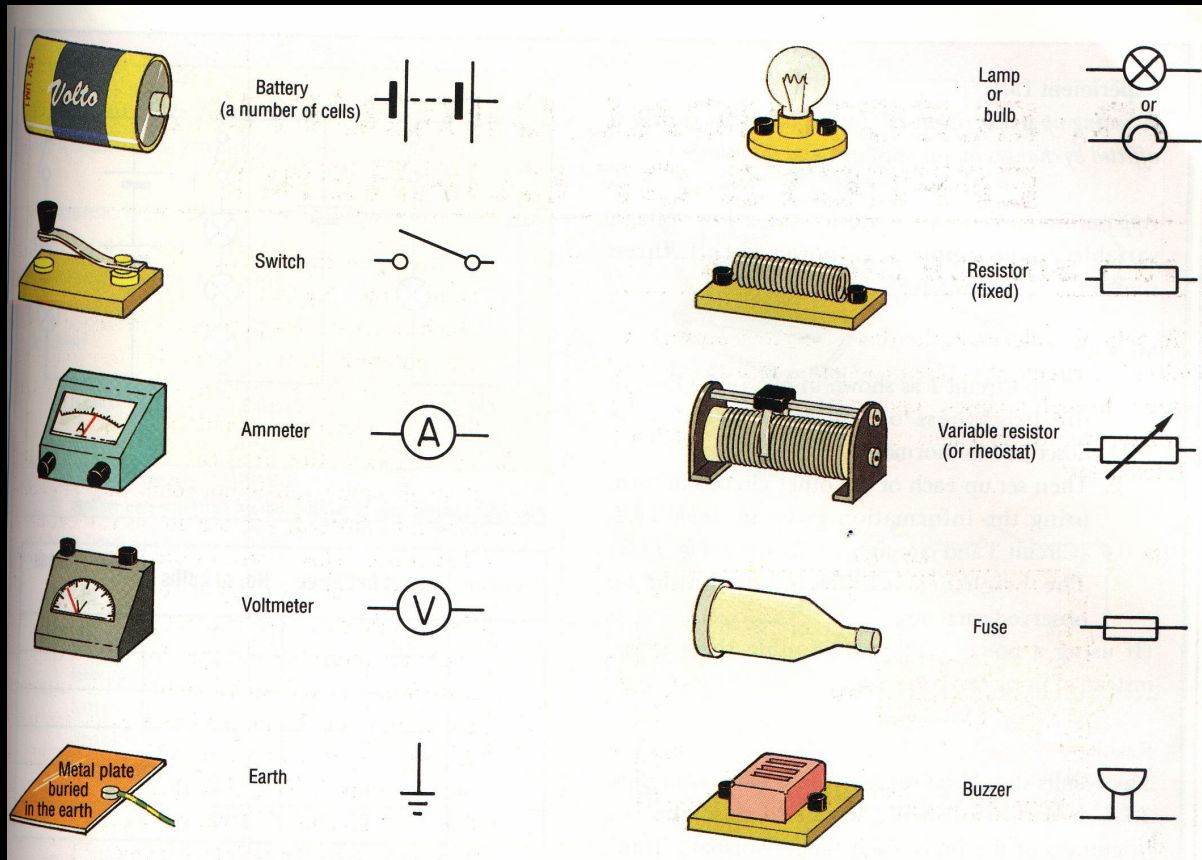

“Complicated” Circuits

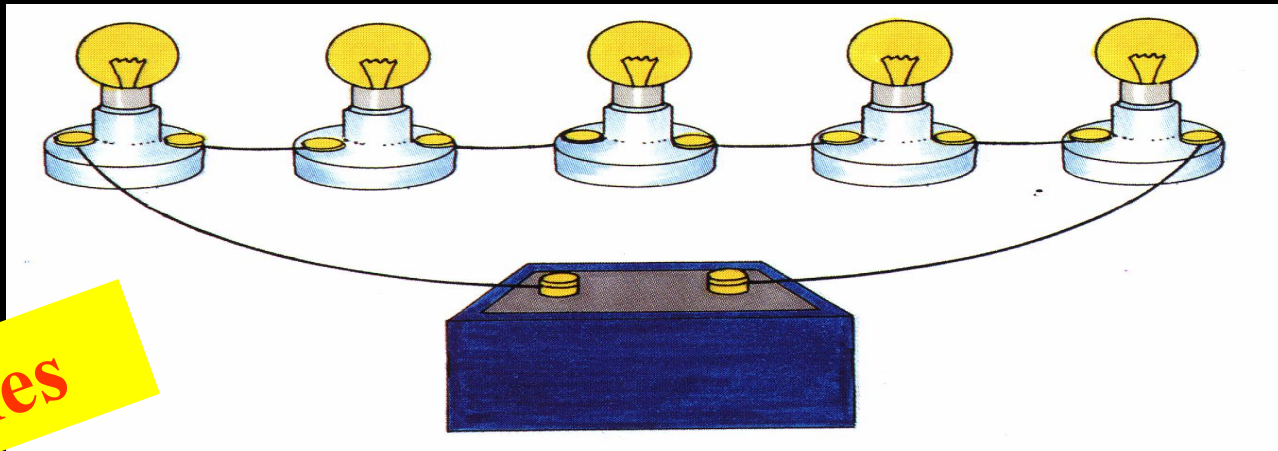

Series

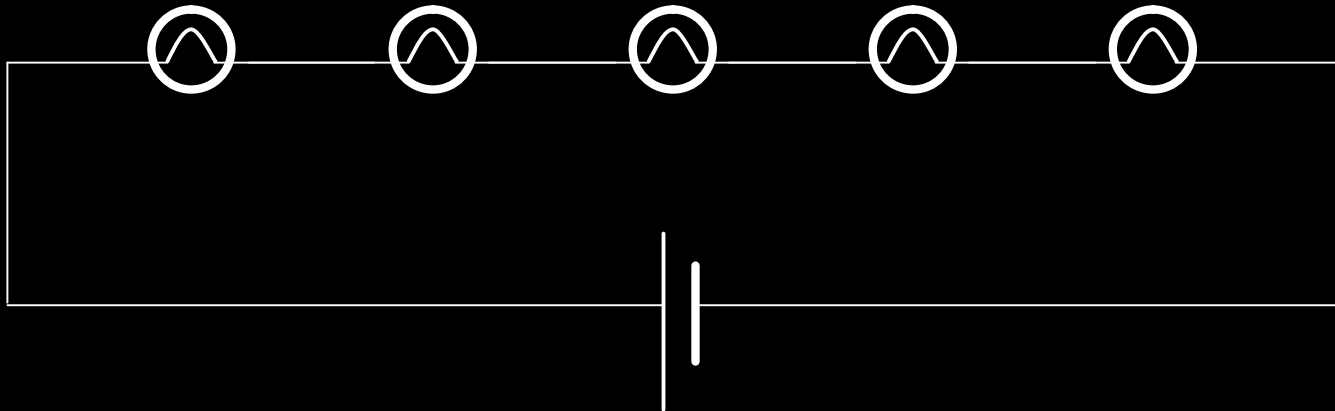

“Complicated” Circuits

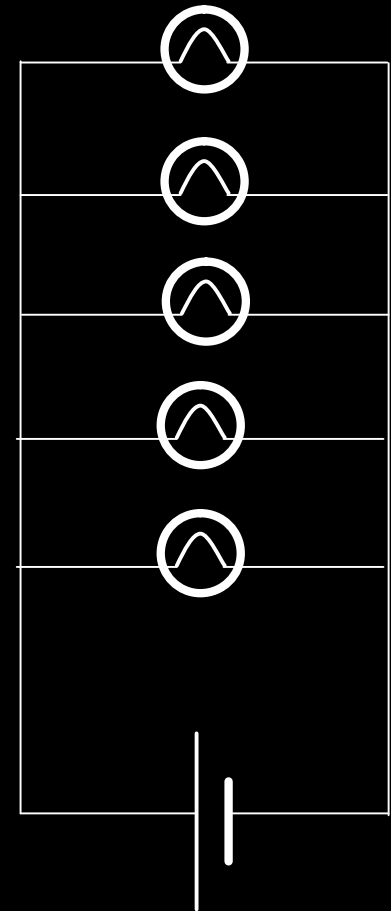
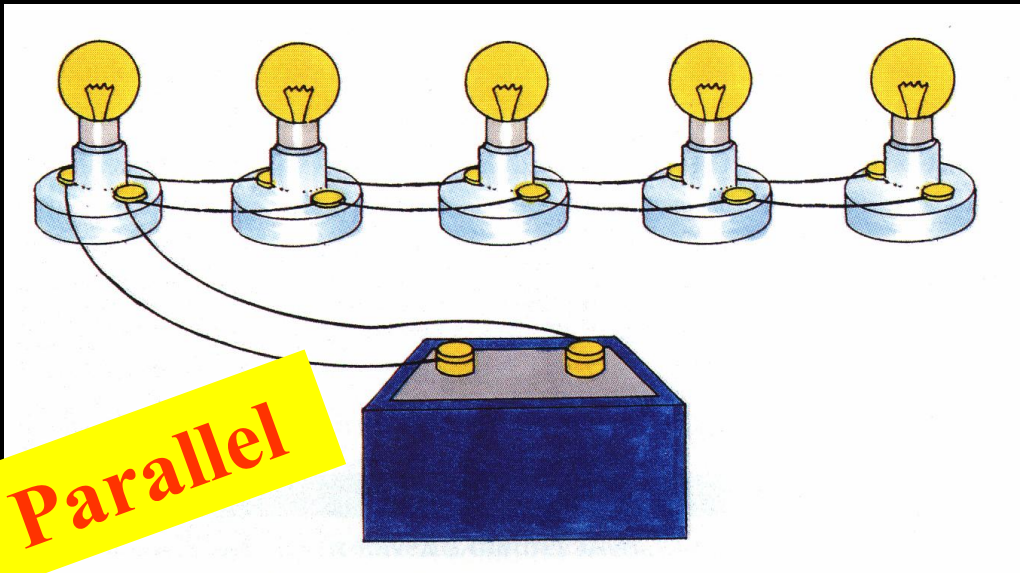

“Complicated” Circuits

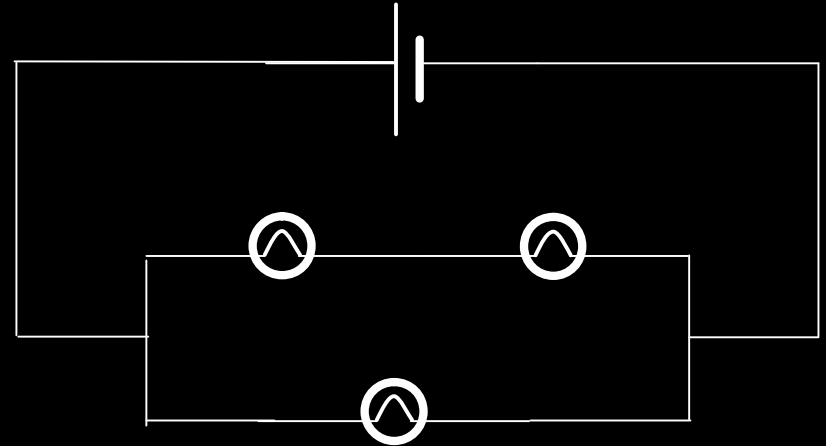
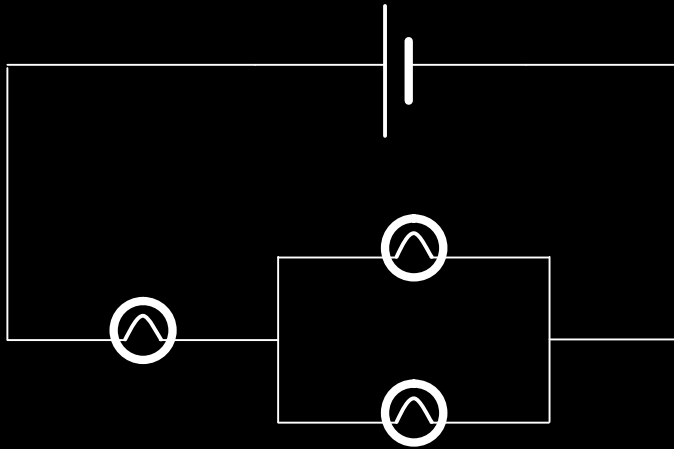

Series / Parallel

Series Circuits

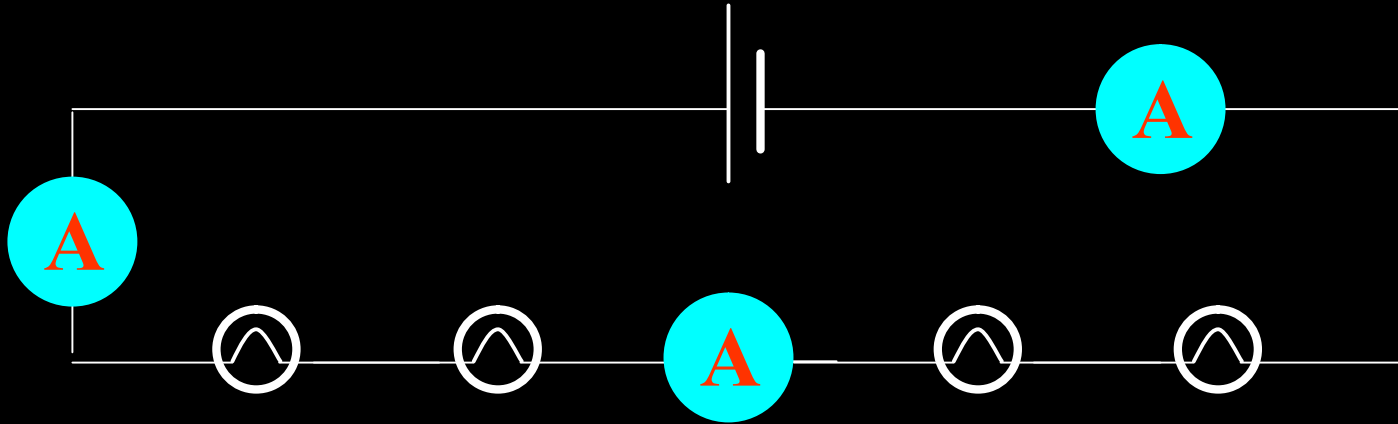

Same current everywhere ...

Series Circuits

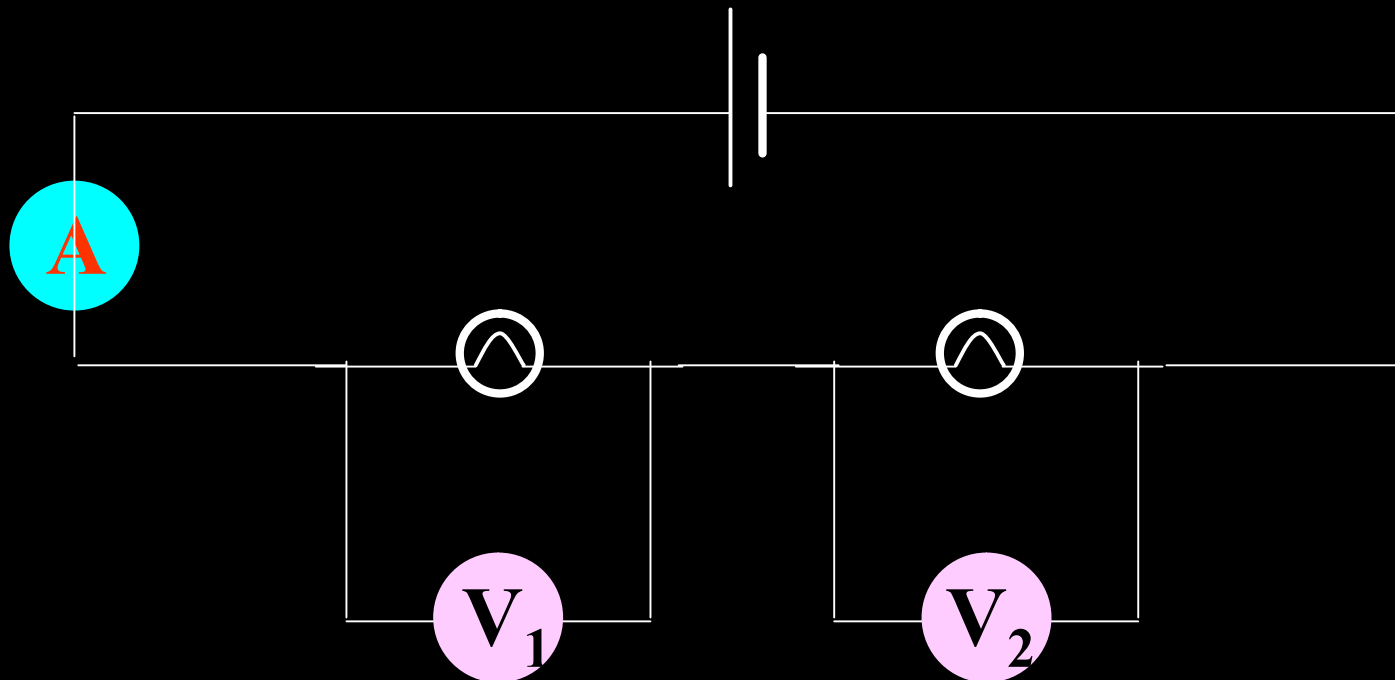

$V_1 \neq V_2$

Series Circuits

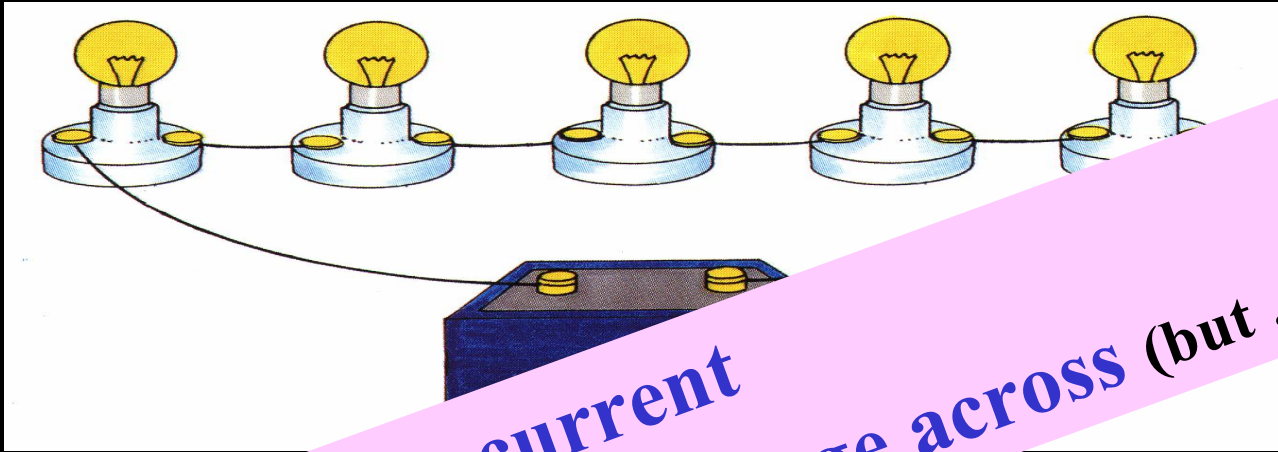

Each lamp

same current

different voltage across (but ...)

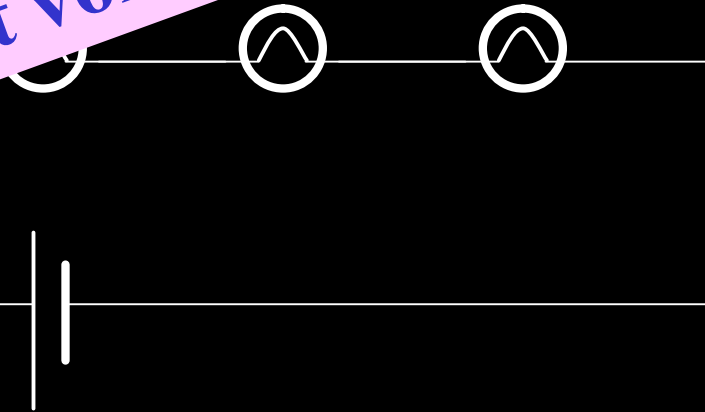

Parallel Circuits

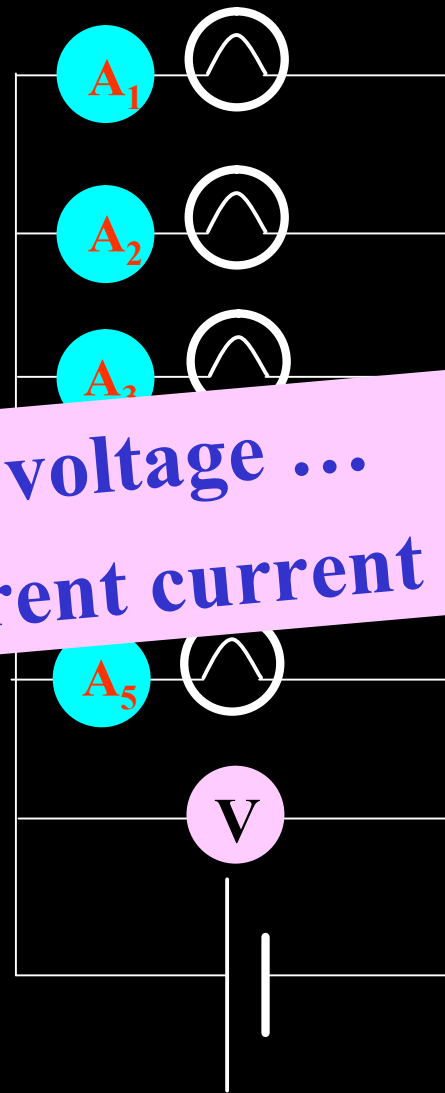

Each lamp

same voltage ...

different current ...

Ohm's Law

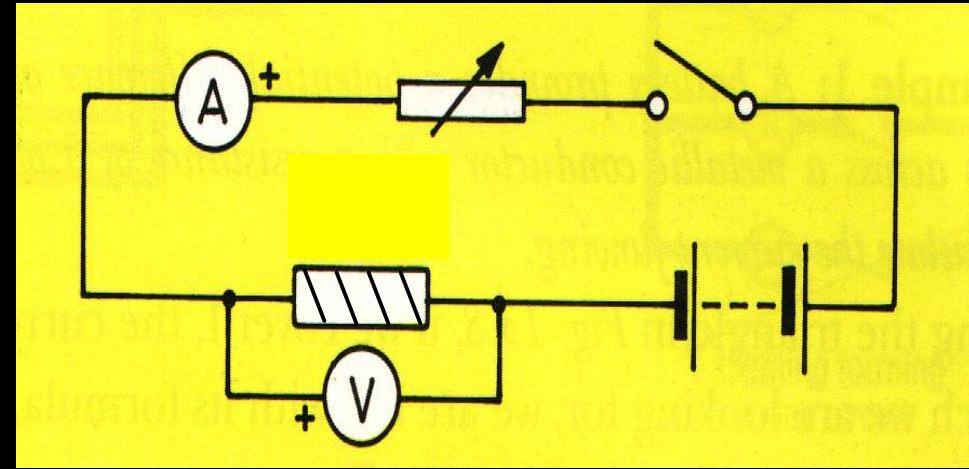
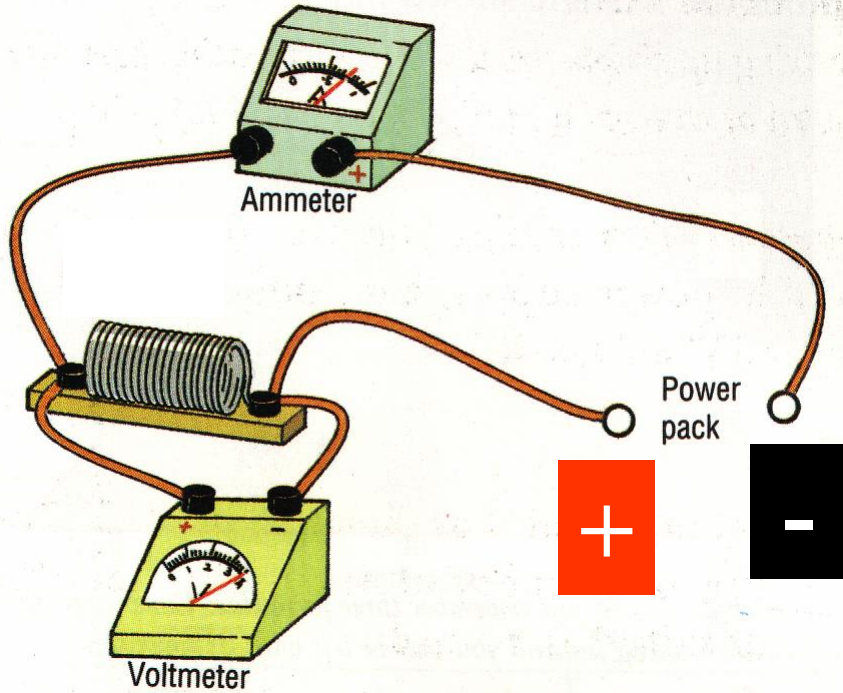

Measure V and I
repeatedly ...

Ohm's Law

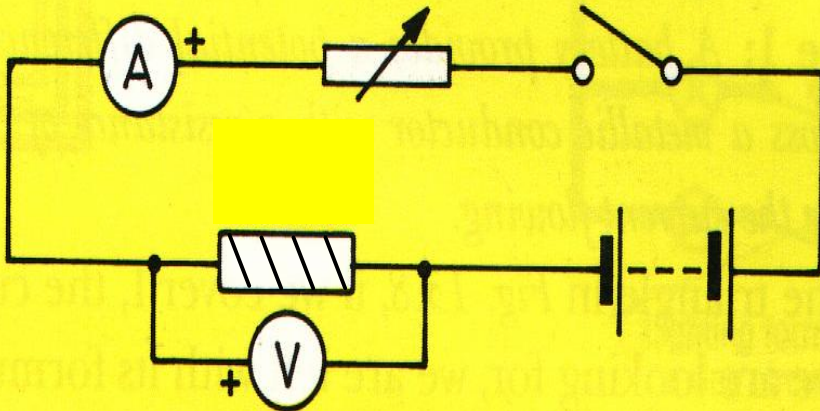

Measure V and I
repeatedly ...

V / V	I / A	$V \div I$
1.0	0.24	4.2
2.0	0.50	4.0
3.0	0.74	4.1
4.0	1.00	4.0
5.0	1.26	4.0
6.0	1.45	4.1
7.0	1.75	4.0
8.0	2.00	4.0

Conclusion

$V \div I = \text{a constant}$

Ohm's Law

or ...

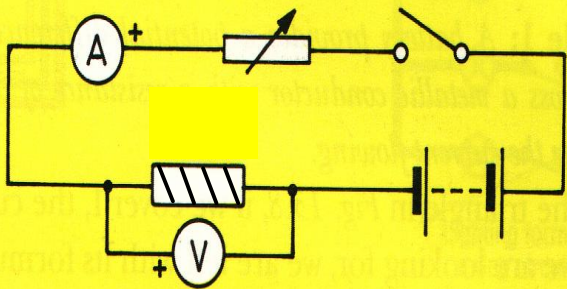

V / V	I / A
1.0	0.24
2.0	0.50
3.0	0.74
4.0	1.00
5.0	1.26
6.0	1.45
7.0	1.75
8.0	2.00

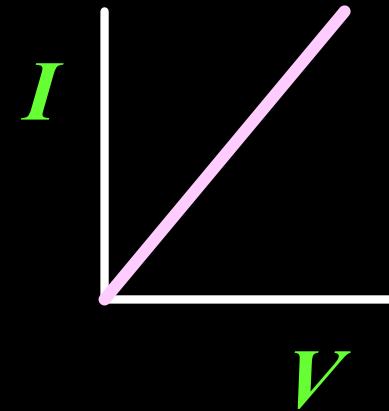

Measure V and I
repeatedly ...

Conclusion:

Straight line through the origin

→ I is directly proportional to V

Ohm's Law

- **Current** is directly proportional to **potential difference**
- for a conductor at **constant temperature**

or ...

- **Potential difference** divided by **current** = a constant
- for a conductor at **constant temperature**

Ohm's Law

$$V \div I = \text{a constant}$$

$$V \div I = R$$

Resistors In Series

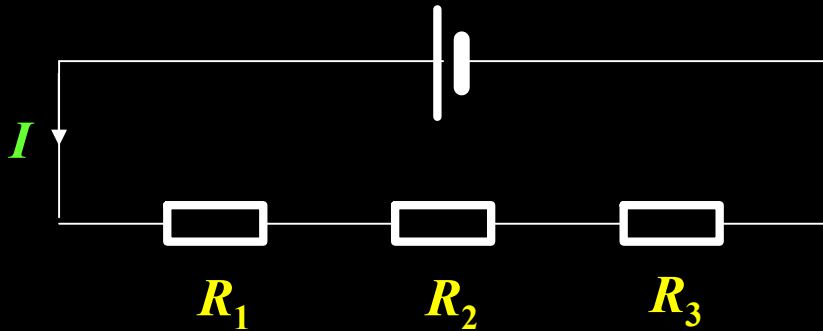

Same I ...

$$V = V_1 + V_2 + V_3$$

$$IR = IR_1 + IR_2 + IR_3$$

$$R = R_1 + R_2 + R_3$$

Resistors In Parallel

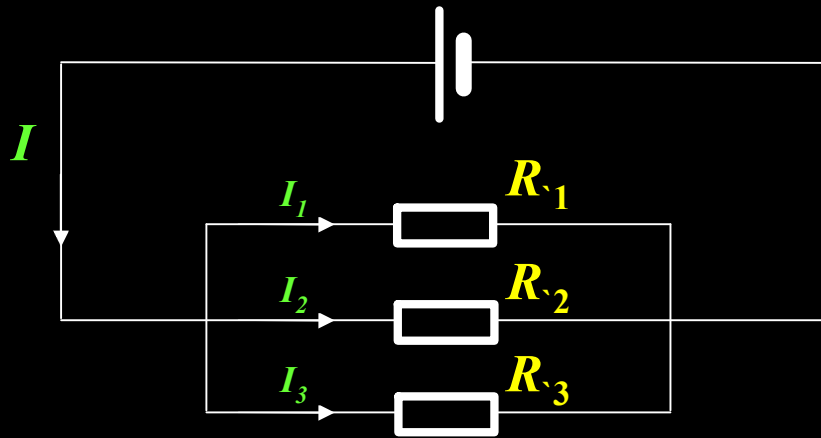

A diagram showing three resistors connected in parallel to a voltage source V . The voltage source is represented by a vertical line with a small gap at the top. The resistors are represented by three horizontal rectangles stacked vertically. A yellow box highlights the text "Same V ..." and the equations $I = I_1 + I_2 + I_3$, $V/R = V/R_1 + V/R_2 + V/R_3$, and $1/R = 1/R_1 + 1/R_2 + 1/R_3$. A yellow box below the diagram says "Same V ".

Same V ...

$$I = I_1 + I_2 + I_3$$
$$V/R = V/R_1 + V/R_2 + V/R_3$$
$$1/R = 1/R_1 + 1/R_2 + 1/R_3$$

Same V

Calculate, (i) the circuit resistance,
(ii) the current and *pd* for each resistor.

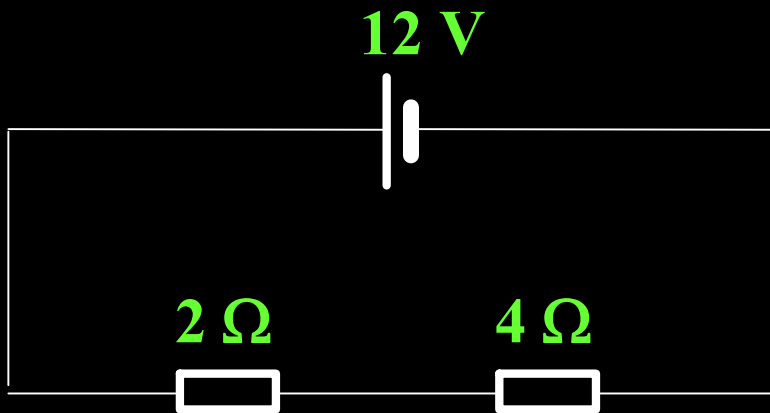

$$(i) \quad R = R_1 + R_2$$

$$R = 2 + 4 = 6 \Omega$$

$$(ii) \quad I = V \div R = 12 \div 6$$

$$= 2 \text{ A} = I_2 = I_4$$

$$V_2 = (IR) = 2 \times 2 = 4 \text{ V}$$

$$V_4 = (IR) = 2 \times 4 = 8 \text{ V}$$

or Divide 12 V in the ratio 2:4

Calculate, (i) the circuit resistance,
(ii) the current and *pd* for each resistor.

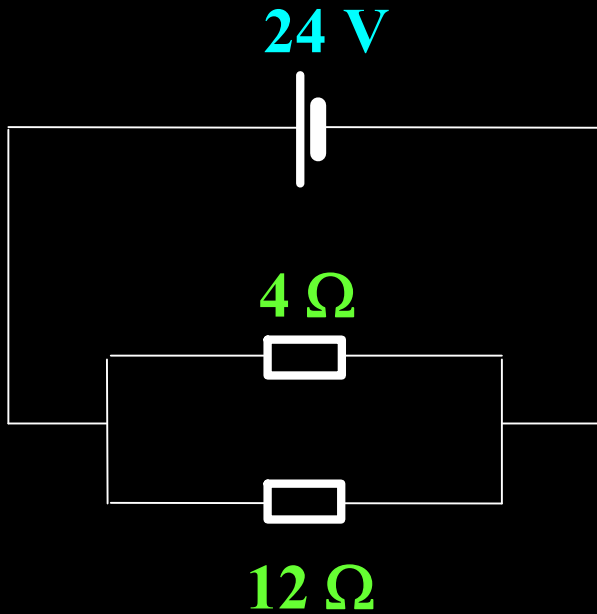

(i) $1/R = 1/R_1 + 1/R_2$

$$1/R = 1/4 + 1/12$$

$$\rightarrow R = 3 \Omega$$

(ii) $V_4 = V_{12} = 24 \text{ V}$

$$I_4 = (V \div R) = 24 \div 4 = 6 \text{ A}$$

$$I_{12} = (V \div R) = 24 \div 12 = 2 \text{ A}$$

Calculate, (i) the circuit resistance,
(ii) the current and *pd* for each resistor.

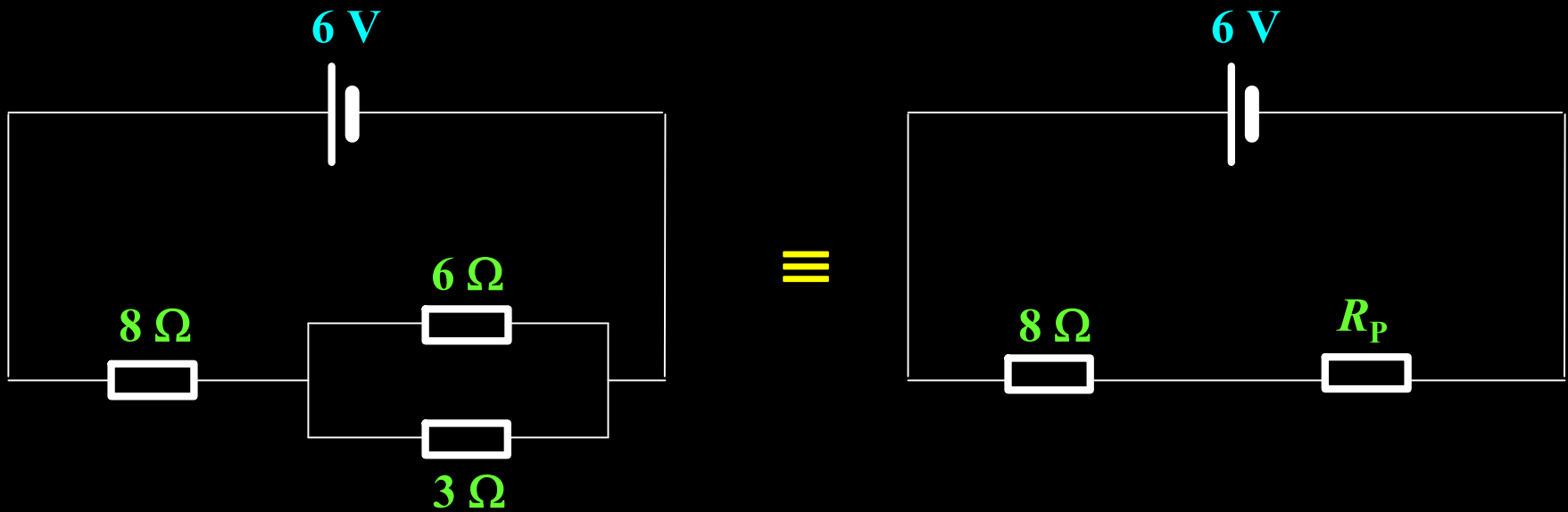

(i) Parallel: $1/R_P = 1/6 + 1/3 \rightarrow R_P = 2 \Omega$

Circuit: $R = 8 + 2 = 10 \Omega$

Calculate, (i) the circuit resistance,
(ii) the current and *pd* for each resistor.

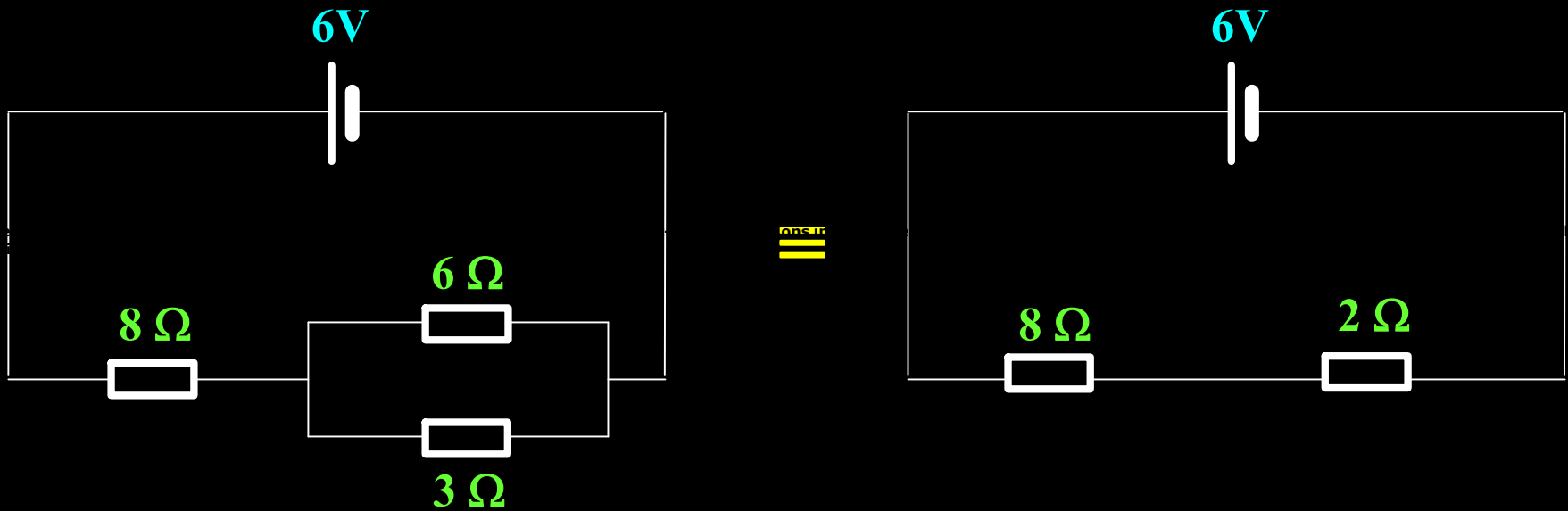

(ii) Circuit:
$$I = V \div R = 6 \div 10 = 0.6 \text{ A}$$

$$= I_8$$

Divide 6 V in the ratio 8:2

$\rightarrow 4.8 \text{ V} \ \& \ 1.2 \text{ V}$

$\rightarrow V_8 = 4.8 \text{ V} \quad V_2 = V_6 = V_3 = 1.2 \text{ V}$

Calculate, (i) the circuit resistance,
(ii) the current and *pd* for each resistor.

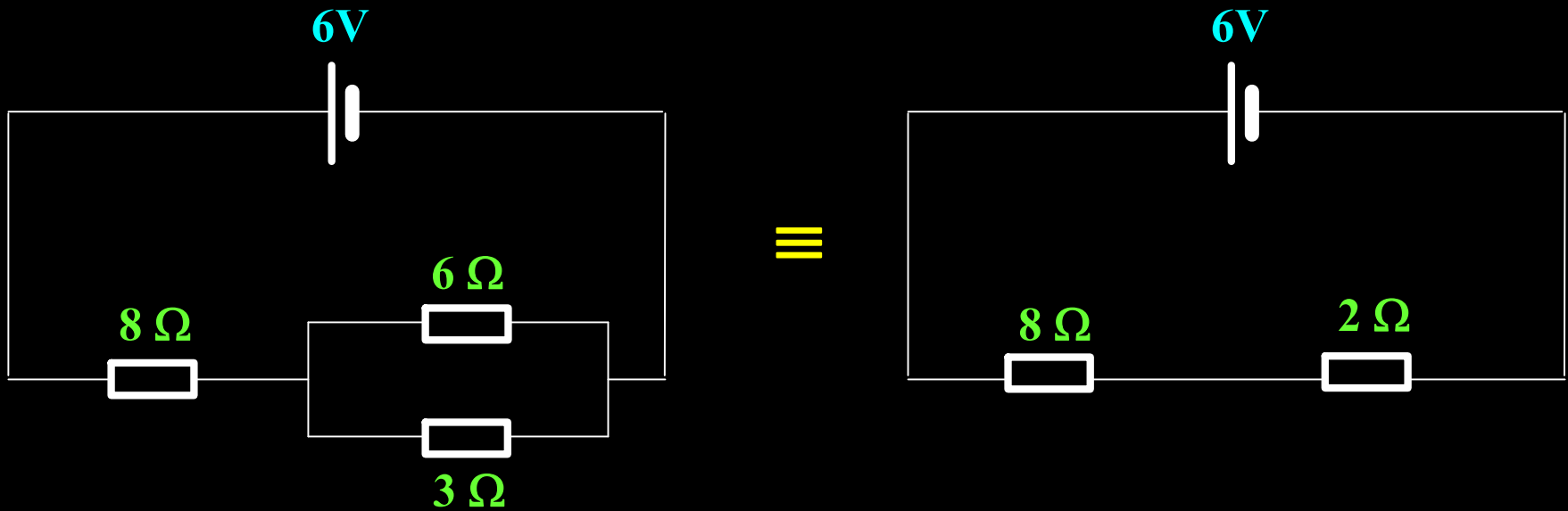

$$\begin{aligned}
 \text{(ii)} \quad I_6 &= (V \div R) &= 1.2 \div 6 &= 0.2 \text{ A} \\
 I_3 &= (V \div R) &= 1.2 \div 3 &= 0.4 \text{ A}
 \end{aligned}$$

Note: $I_8 = I_6 + I_3$