

Chapter 7

Acceleration

Uniform Acceleration

Rate of change of velocity (w.r.t. time)

Change in velocity in unit time

Acceleration = (change in velocity) ÷ time

Symbol: a

Units: m s^{-2}

Uniform Acceleration

Velocity is a vector

Therefore ... a body accelerates if ...

... its velocity changes in magnitude

or

... its velocity changes in direction

Ferrari

Changing magnitude



4.8 seconds

0 to 100 km h⁻¹

Changing direction



Equations Of Motion

$$v = u + at$$

$$s = ut + \frac{1}{2}at^2$$

$$v^2 = u^2 + 2as$$

a = acceleration

u = initial velocity

v = final velocity

s = displacement

t = time

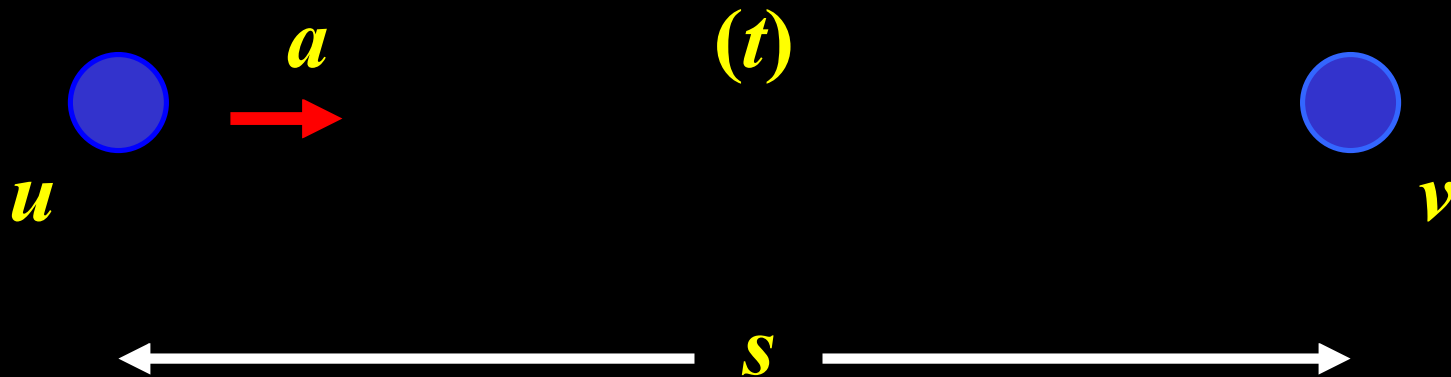

Deriving $v = u + at$

$a = \text{change in velocity} \div \text{time}$

$$a = (v - u) \div t$$

$$v = u + at$$

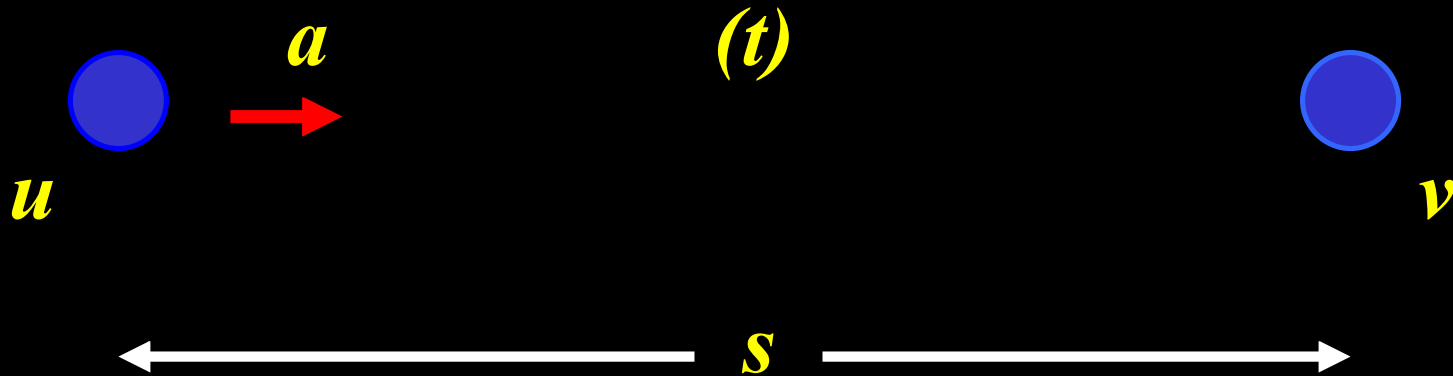

Deriving: $s = ut + \frac{1}{2}at^2$

$$s = (\text{average velocity}) \times \text{time}$$

$$s = \frac{1}{2} (u + v) t \quad [\text{average velocity} = \frac{1}{2} (u + v)]$$

$$s = \frac{1}{2} (u + u + at) t$$

$$s = ut + \frac{1}{2}at^2$$

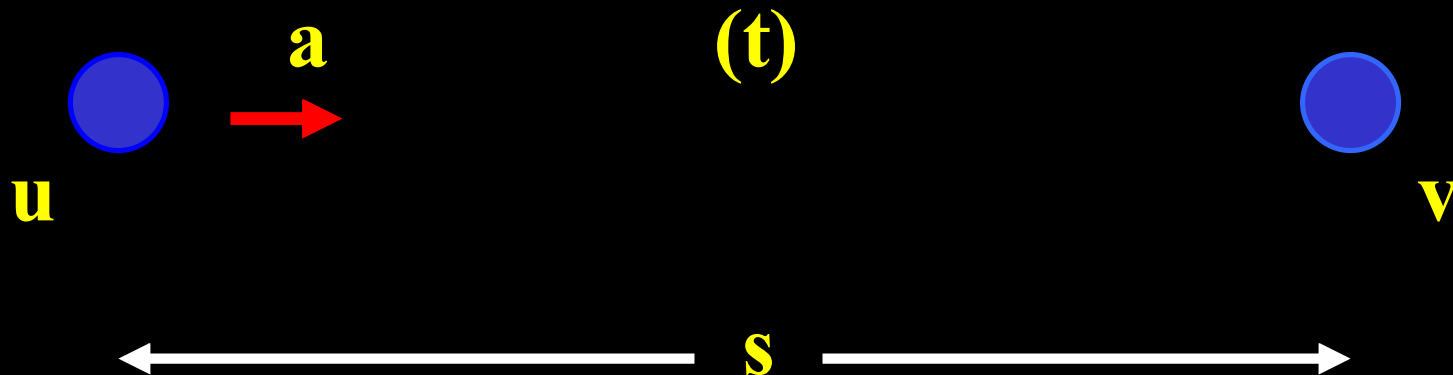

Deriving: $v^2 = u^2 + 2as$

$$v = u + at$$

$$v^2 = (u + at)^2$$

$$v^2 = u^2 + 2 \cdot u \cdot at + a^2 t^2$$

$$v^2 = u^2 + 2a(ut + \frac{1}{2}at^2)$$

$$v^2 = u^2 + 2as$$

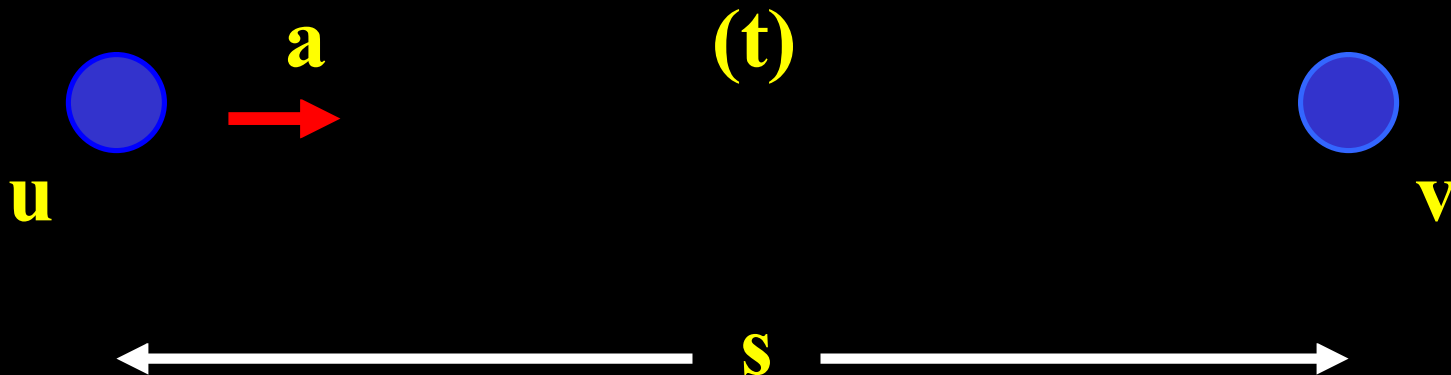

P1 The velocity of a car increases from 10 m s^{-1} East to 40 m s^{-1} East in 5 seconds.

Calculate the average acceleration of the car.

East = + direction

$$\text{Average acceleration} = \frac{\text{final velocity} - \text{initial velocity}}{\text{time taken}}$$

$$\text{Average acceleration} = \frac{(+40) - (+10)}{5} = 6 \text{ m s}^{-2} \text{ East}$$

P2 The speed of a bicycle moving in a straight line decreases from 15 m s^{-1} North to 3 m s^{-1} North in 6 s. Find its average acceleration.

North = + direction

$$\text{Average acceleration} = \frac{\text{final velocity} - \text{initial velocity}}{\text{time taken}}$$

$$\text{Average acceleration} = \frac{(+3) - (+15)}{6} = -2 \text{ m s}^{-2}$$

$$2 \text{ m s}^{-2} \text{ South}$$

P3 A car starting from rest has an acceleration of 4 m s^{-2} .
Find: (i) its velocity after 8 s,
(ii) the distance it travels in 8 s,
(iii) how long it takes to reach a velocity of 100 m s^{-1} .

(i) Forward = + direction

$$u = 0, \quad a = +4, \quad t = 8, \quad v = ??$$

$$v = u + at$$

$$v = 0 + (+4)(8)$$

$$v = +32 \text{ m s}^{-1}$$

P3 A car starting from rest has an acceleration of 4 m s^{-2} .
Find: (i) its velocity after 8 s,
(ii) the distance it travels in 8 s,
(iii) how long it takes to reach a velocity of 100 m s^{-1} .

(ii) Forward = + direction

$$u = 0, \quad a = +4, \quad t = 8, \quad s = ??$$

$$s = ut + \frac{1}{2} at^2$$

$$s = 0 + \frac{1}{2} (+4)(8)^2$$

$$s = 128 \text{ m}$$

P3 A car starting from rest has an acceleration of 4 m s^{-2} .
Find: (i) its velocity after 8 s,
(ii) the distance it travels in 8 s,
(iii) how long it takes to reach a velocity of 100 m s^{-1} .

(iii) Forward = + direction

$$u = 0, \quad a = +4, \quad v = +100, \quad t = ??$$

$$v = u + at$$

$$+100 = 0 + (+4)(t)$$

$$t = 25 \text{ s}$$

P4 A car with constant acceleration travels a distance of 100 m while its velocity changes from 10 m s⁻¹ to 25 m s⁻¹. Calculate its acceleration.

Forward = + direction

$$u = +10, \quad v = +25, \quad s = +100, \quad a = ??$$

$$v^2 = u^2 + 2as$$

$$(+25)^2 = (+10)^2 + 2a(+100)$$

$$a = 2.63 \text{ m s}^{-2}$$

P5 A car travelling with a speed of 10 m s^{-1} passes a pole on the roadside at a certain instant. It immediately accelerates with an acceleration of 2 m s^{-2} . How far is it from the pole when its velocity is 30 m s^{-1} ?

Forward = + direction

$$u = +10, \quad v = +30, \quad a = +2, \quad s = ??$$

$$v^2 = u^2 + 2as$$

$$(+30)^2 = (+10)^2 + 2(+2)s$$

$$s = +200 \text{ m}$$

P6 A train which has a constant acceleration travels a distance of 2 km in 50 s. If its initial velocity is 20 m s⁻¹, find its acceleration.

Forward = + direction

$$u = +20, \quad s = +2000, \quad t = +50, \quad a = ??$$

$$s = ut + \frac{1}{2} at^2$$

$$2000 = (+20)(+50) + \frac{1}{2}a(50)^2$$

$$a = +0.80 \text{ m s}^{-2}$$

Velocity - Time Graphs

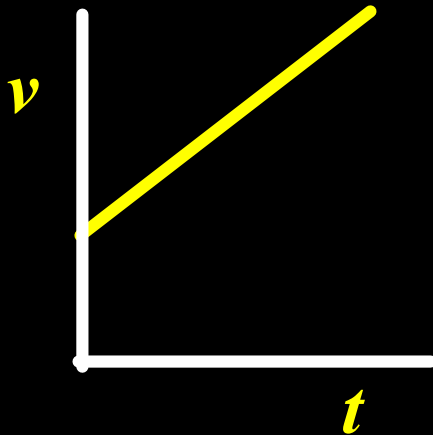

Slope = ??
Acceleration

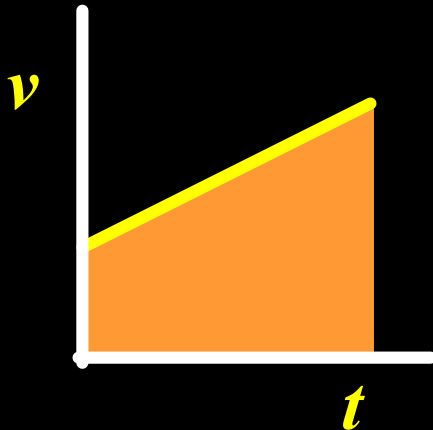

Area under graph = ??
Distance travelled

Velocity - Time Graphs

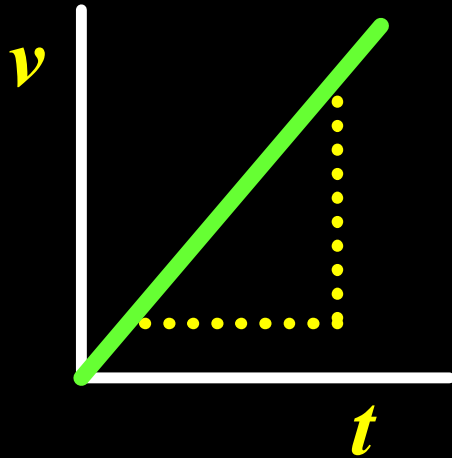

$$\text{Slope} = \frac{\Delta v}{\Delta t}$$

Slope = acceleration (a)

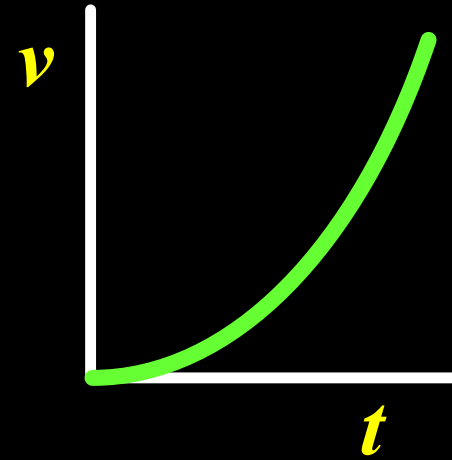

**Acceleration
increasing**

Velocity - Time Graphs

Comment

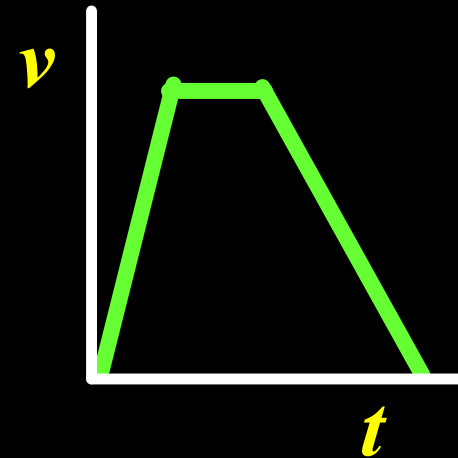
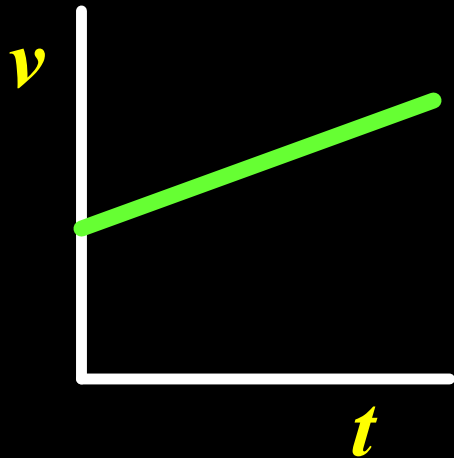
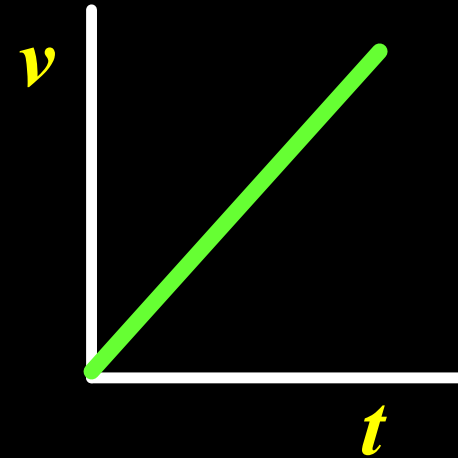
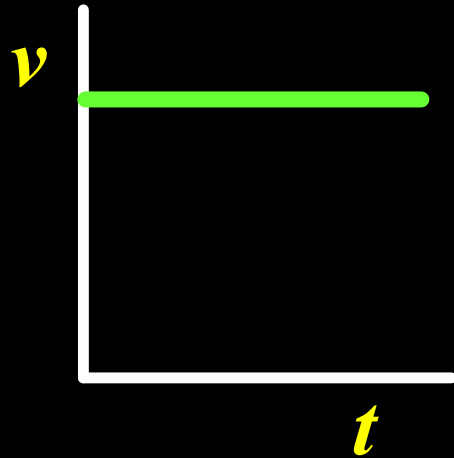

Velocity - Time Graphs

Comment

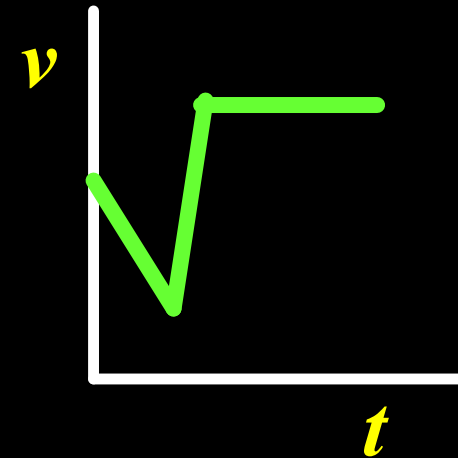
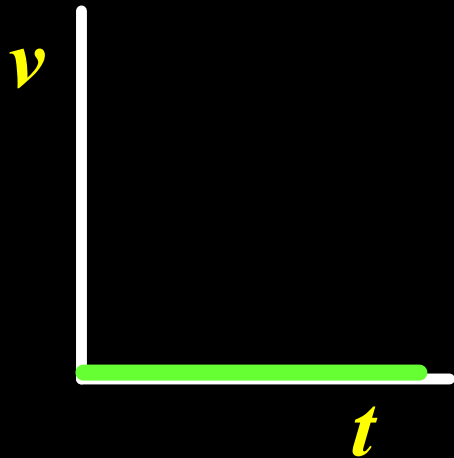
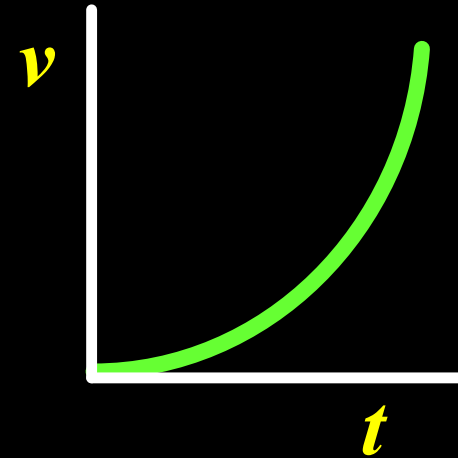
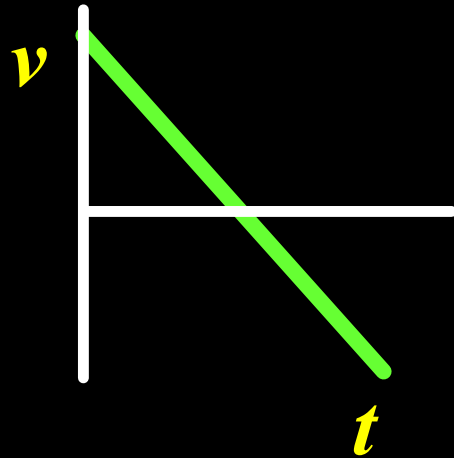

Measuring Velocity & Acceleration

Powder Track Timer

Air Track Timer

Ticker Tape Timer

Powder Track Timer



Trolley

A.C. Power Supply

Track

Sulphur Powder

PTT - Measuring Velocity

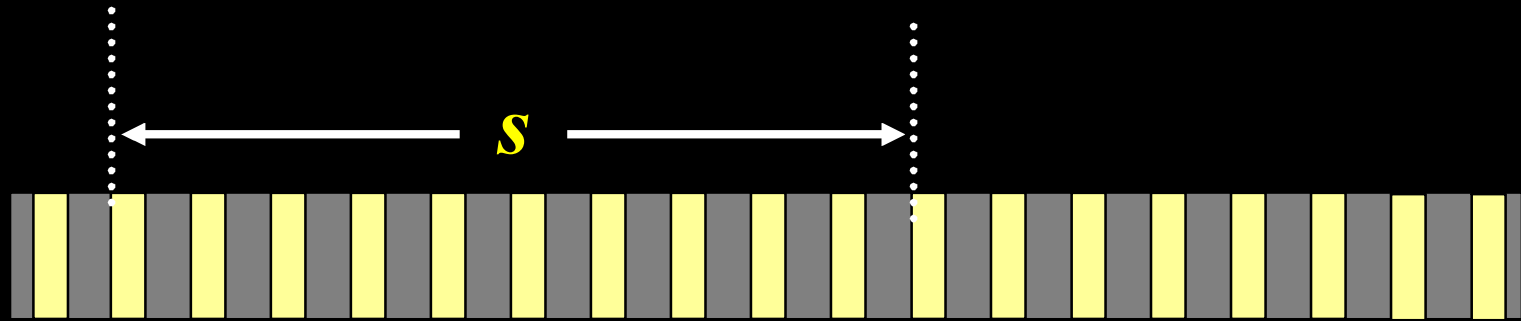

$$\text{Velocity} = \text{spread of 10 patches} \div (10 \times 0.02)$$

PTT - Measuring Acceleration



$$v = u + at$$

u = spread of 5 patches near the start $\div (5 \times 0.02)$

v = spread of 5 patches near the end $\div (5 \times 0.02)$

t = “ n ” $\times 0.02$

PTT - Measuring Acceleration



or

$$v^2 = u^2 + 2as$$

u = spread of 5 patches near the start $\div (5 \times 0.02)$

v = spread of 5 patches near the end $\div (5 \times 0.02)$

s = distance from

middle of u patches to middle of v patches

PTT - Precautions

- **Wedge ... to compensate for ??**
- **u and v well apart**
- **Repeat for other patches ...**
- **Velocity ... use more than 10 patches**

Ticker-Tape Timer

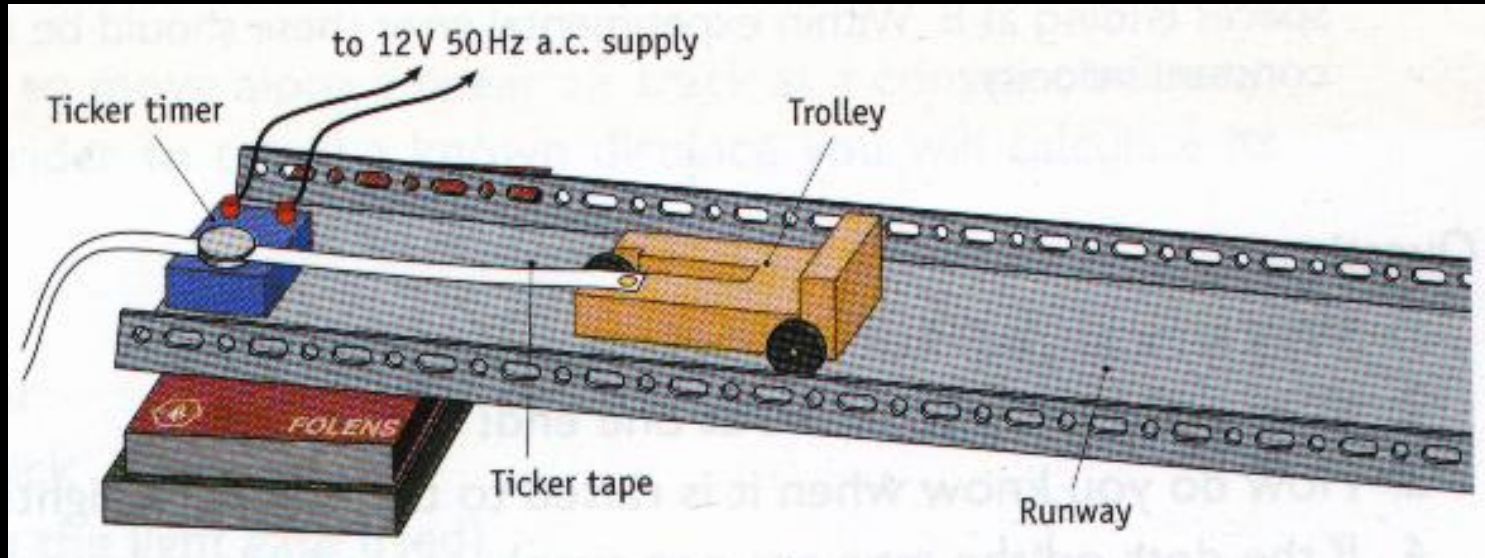

Ticker-Tape Timer

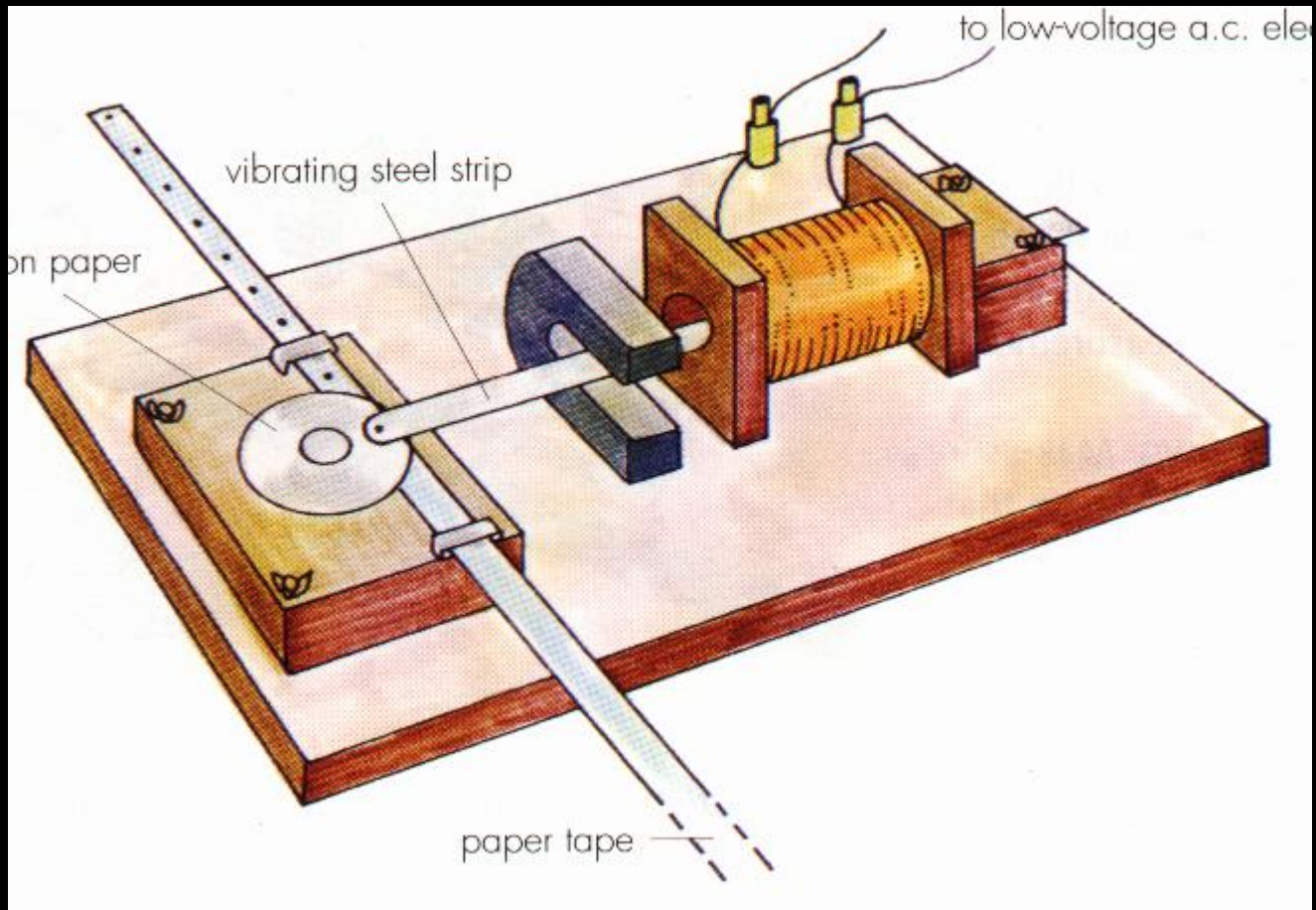

Ticker-Tape Timer

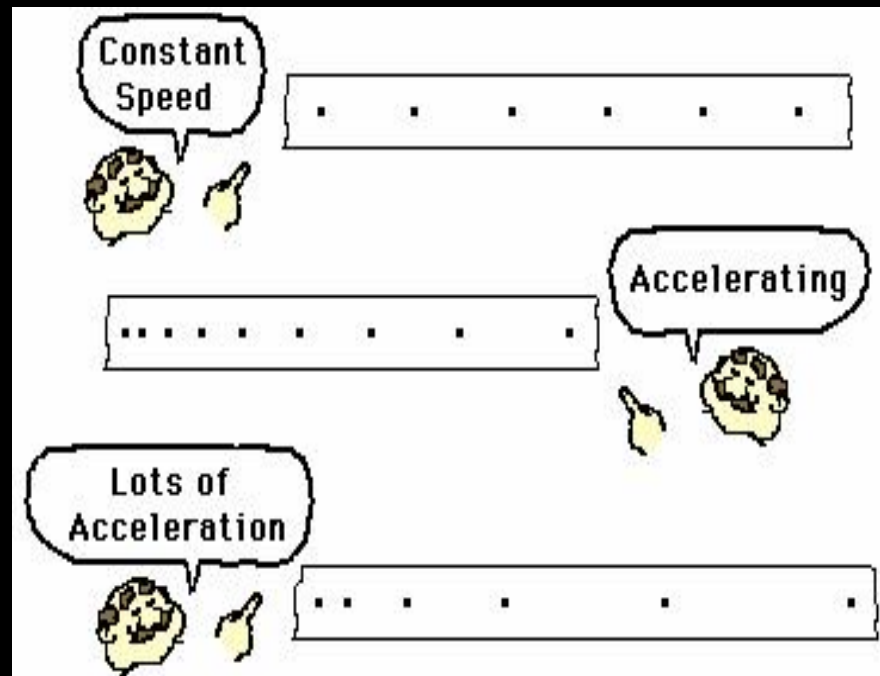

TTT - Measuring Acceleration

$$v = u + at$$

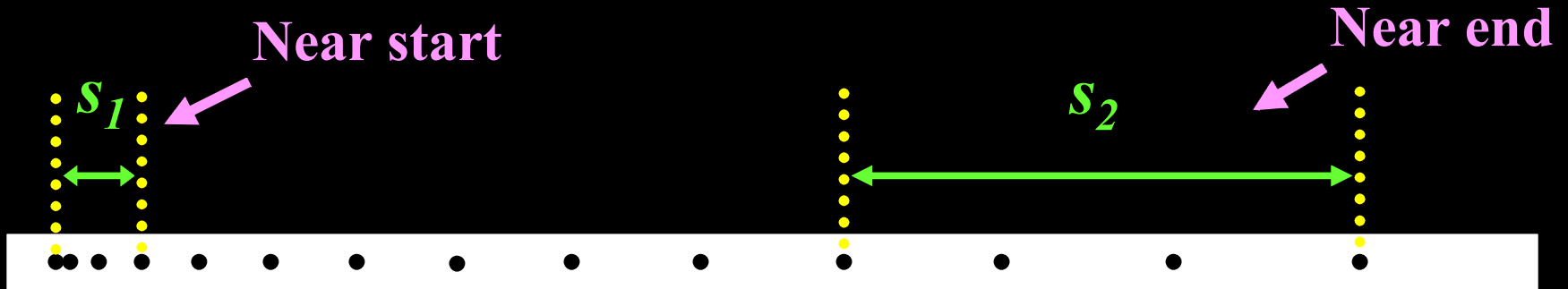

$$u = \frac{S_1}{3 \times 0.02}$$

$$t = "n" \times 0.02$$

$$v = \frac{S_2}{3 \times 0.02}$$

$$a = \frac{v - u}{t}$$

TTT - Measuring Acceleration

$$v^2 = u^2 + 2as$$

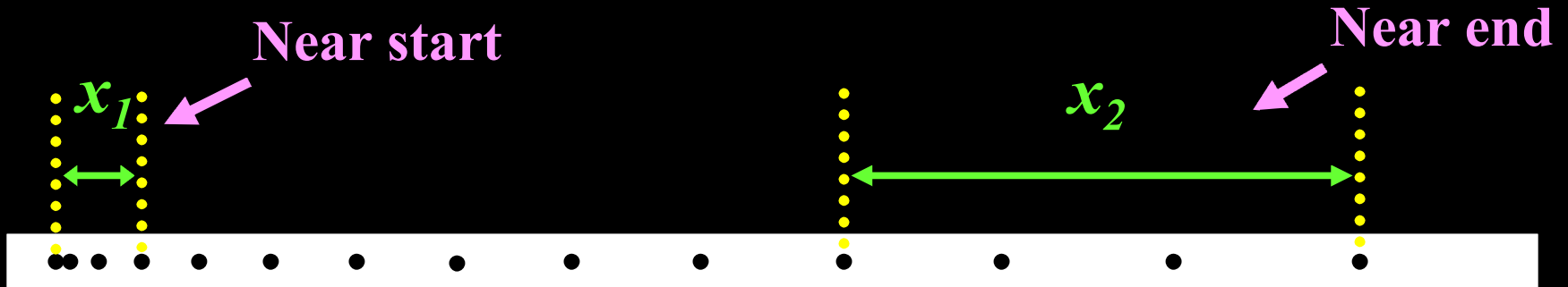

$$u = \frac{x_1}{3 \times 0.02}$$

$$v = \frac{x_2}{3 \times 0.02}$$

s = distance from “middle of u ” to “middle of v ”

$$a = \frac{v^2 - u^2}{2s}$$

Air Track Timer

Measuring Acceleration

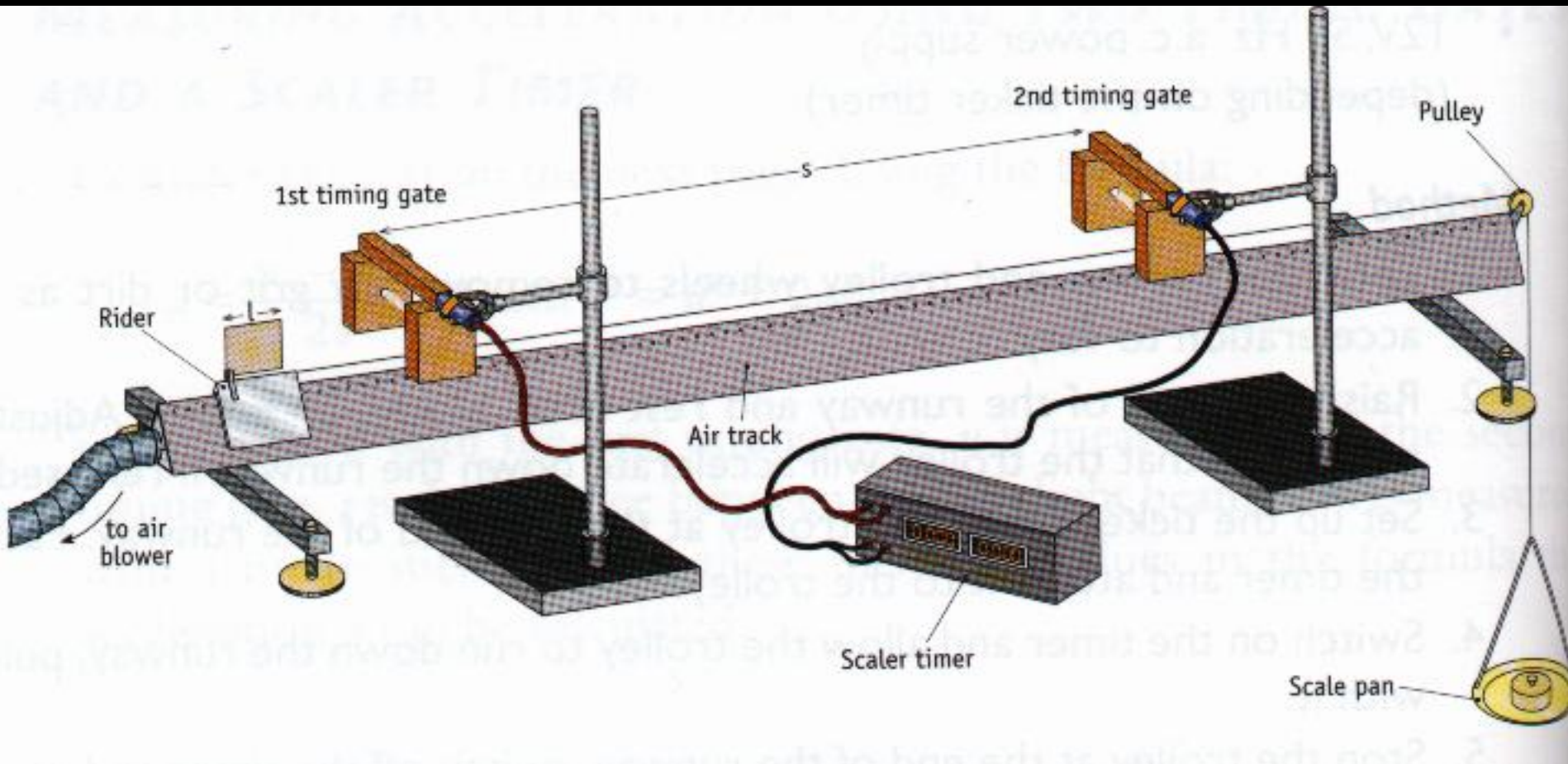

Air Track Timer

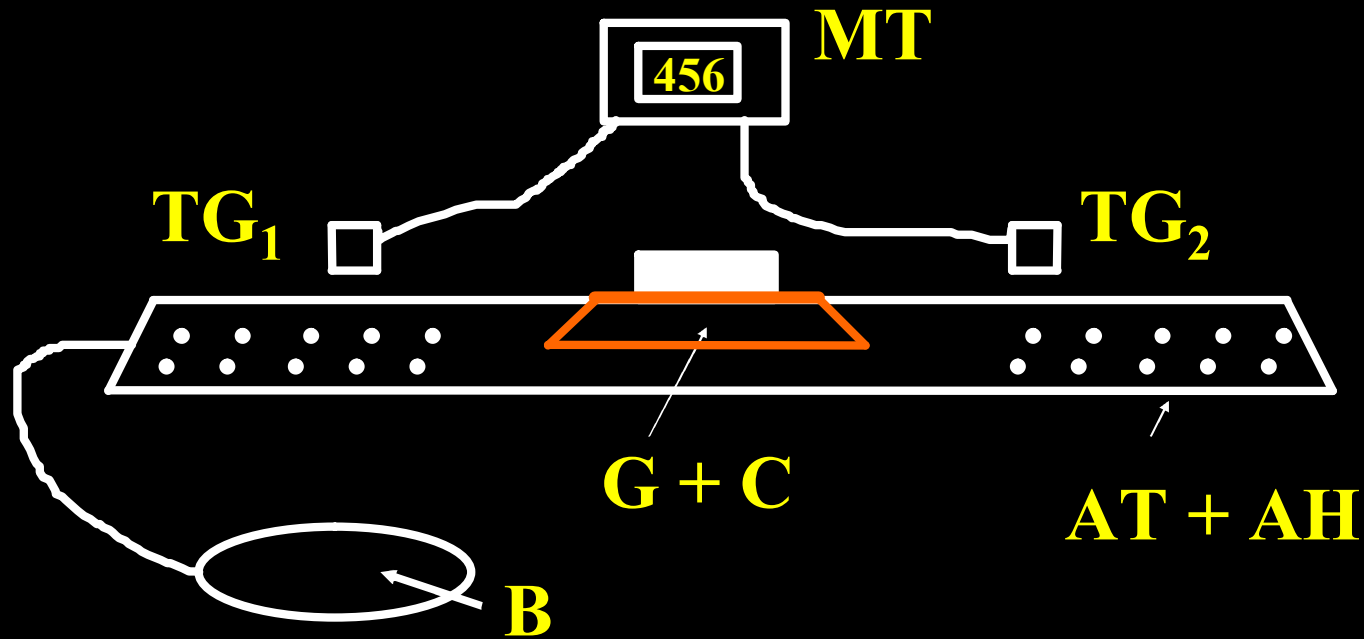

Air Track + Air Holes

Timing Gates

Blower

Glider + Card

Millisecond Timer

Air Track Timer

Measuring Acceleration

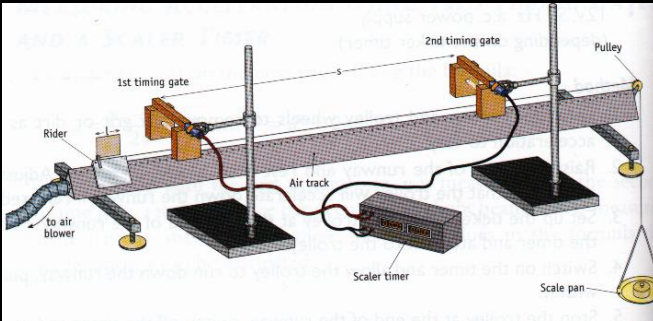

$$v^2 = u^2 + 2as$$

$$u = \frac{\text{width of card}}{\text{time gate 1}}$$

$$v = \frac{\text{width of card}}{\text{time gate 2}}$$

$s = \text{distance from gate 1 to gate 2}$

Precautions

- s large
- strong enough air supply
- repeat other ...

$$a = \frac{v^2 - u^2}{2s}$$

Acceleration Due To Gravity "g"



Galileo Galilei

Italian physicist and
astronomer
(1564-1642)

Father of Experimental Science

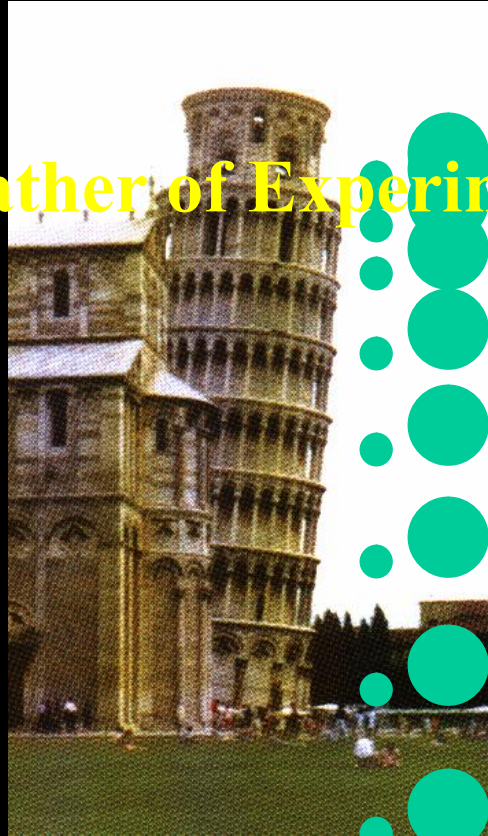

$$g = 9.8 \text{ m s}^{-2}$$

Acceleration Due To Gravity "g"

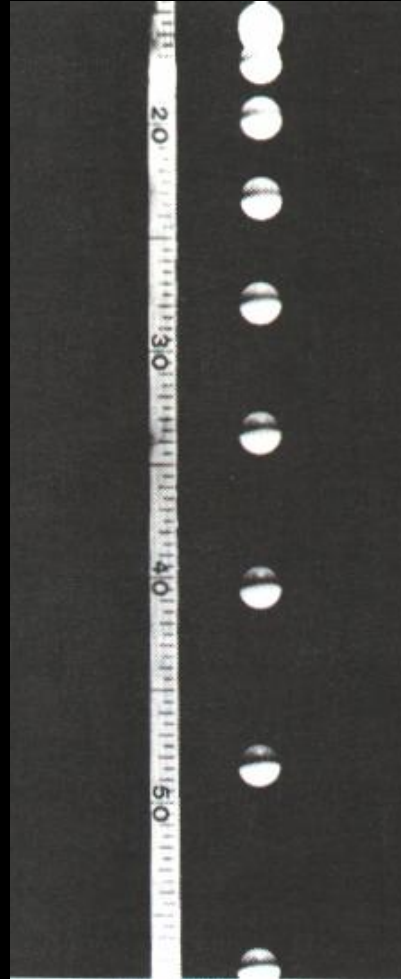
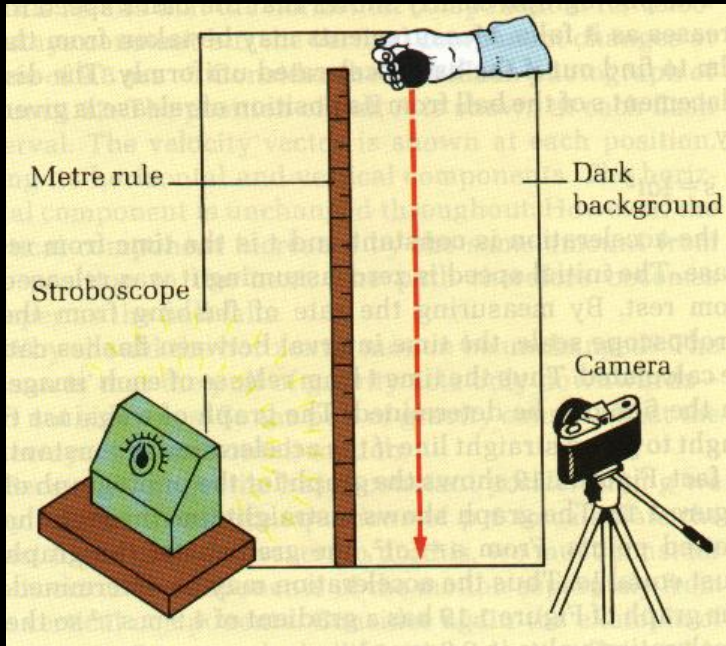

$$g = 9.8 \text{ m s}^{-2}$$

Value of 'g'

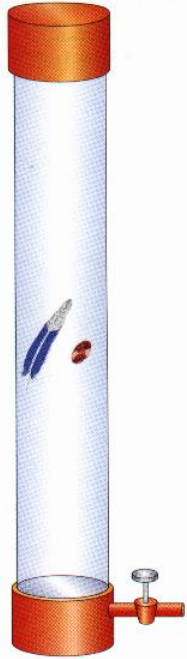

● In a vacuum, a feather and coin fall with the same acceleration and strike the bottom together

Cork	9.81
Equator	9.78
North Pole	9.83
Top Mt. Everest	9.77
Moon	1.6

Value of g depends on ...

- **distance from centre of earth**
- **rotation of the earth**
- **planet, etc.**

P8 An object is dropped from the top of a building which is 30 m high.

(i) With what speed does the object hit the ground?

(ii) How long does it take to reach the ground?

(i) Down = + direction

$$u = 0, \quad s = +30, \quad a = +9.8, \quad v = ??$$

$$v^2 = u^2 + 2as$$

$$v^2 = 0 + 2(+9.8)(+30)$$

$$v = 24.2 \text{ m s}^{-1}$$

P8 An object is dropped from the top of a building which is 30 m high.

(i) With what speed does the object hit the ground?

(ii) How long does it take to reach the ground?

(ii) Down = + direction

$$u = 0, \quad a = +9.8, \quad v = +24.2, \quad t = ??$$

$$v = u + at$$

$$24.2 = 0 + (+9.8) t$$

$$t = 2.47 \text{ s}$$

P9 An object falls from the top of a building and strikes the ground 5 s later.
Find the height of the building.

Down = + direction

$$u = 0, \quad a = +9.8, \quad t = +5, \quad s = ??$$

$$s = ut + \frac{1}{2} at^2$$

$$s = 0 + \frac{1}{2} (+9.8)(+5)^2$$

$$s = 123 \text{ m}$$

P10 A stone is thrown vertically upwards with an initial velocity of 20 m s^{-1} .
Find the greatest height reached by the stone.

Up = + direction

$$u = +20, \quad a = -9.8, \quad v = 0, \quad s = ??$$

$$v^2 = u^2 + 2as$$

$$0 = (+20)^2 + 2(-9.8) s$$

$$s = 20.4 \text{ m}$$

P11 A body is thrown vertically upwards with an initial speed u from a point P which is 20 m above the ground. After 4 s it is at a point Q and has a velocity of 6 m s^{-1} downwards.

Find: (i) the value of u , (ii) the height of Q above ground.

(i) Up = + direction

$$u = ??, \quad a = -9.8, \quad t = +4, \quad v = -6, \quad s = ??$$

$$v = u + at$$

$$-6 = u + (-9.8)(4)$$

$$u = +33.2 \text{ m s}^{-1}$$

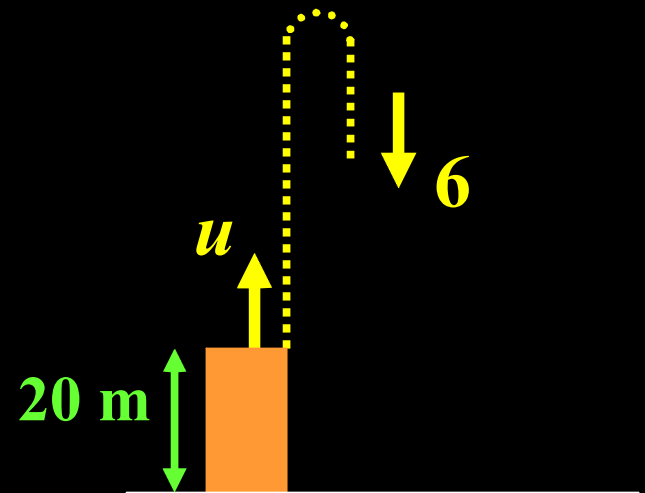

P11 A body is thrown vertically upwards with an initial speed u from a point P which is 20 m above the ground. After 4 s it is at a point Q and has a velocity of 6 m s^{-1} downwards.

Find: (i) the value of u , (ii) the height of Q above ground.

(ii) Up = + direction

$$u = +33.2, \quad a = -9.8, \quad t = +4, \quad s/h = ??$$

$$s = ut + \frac{1}{2} at^2$$

$$s = (+33.2)(+4) + \frac{1}{2} (-9.8)(+4)^2$$

$$s = +54.4 \text{ m}$$

$$\Rightarrow 54.4 \text{ m above P}$$

$$\Rightarrow \text{Height} = 20 + 54.4 = 74.4 \text{ m above ground}$$

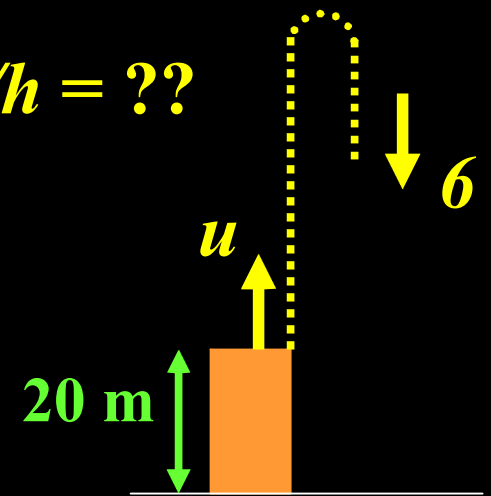

Expt. Measure g by Free-Fall

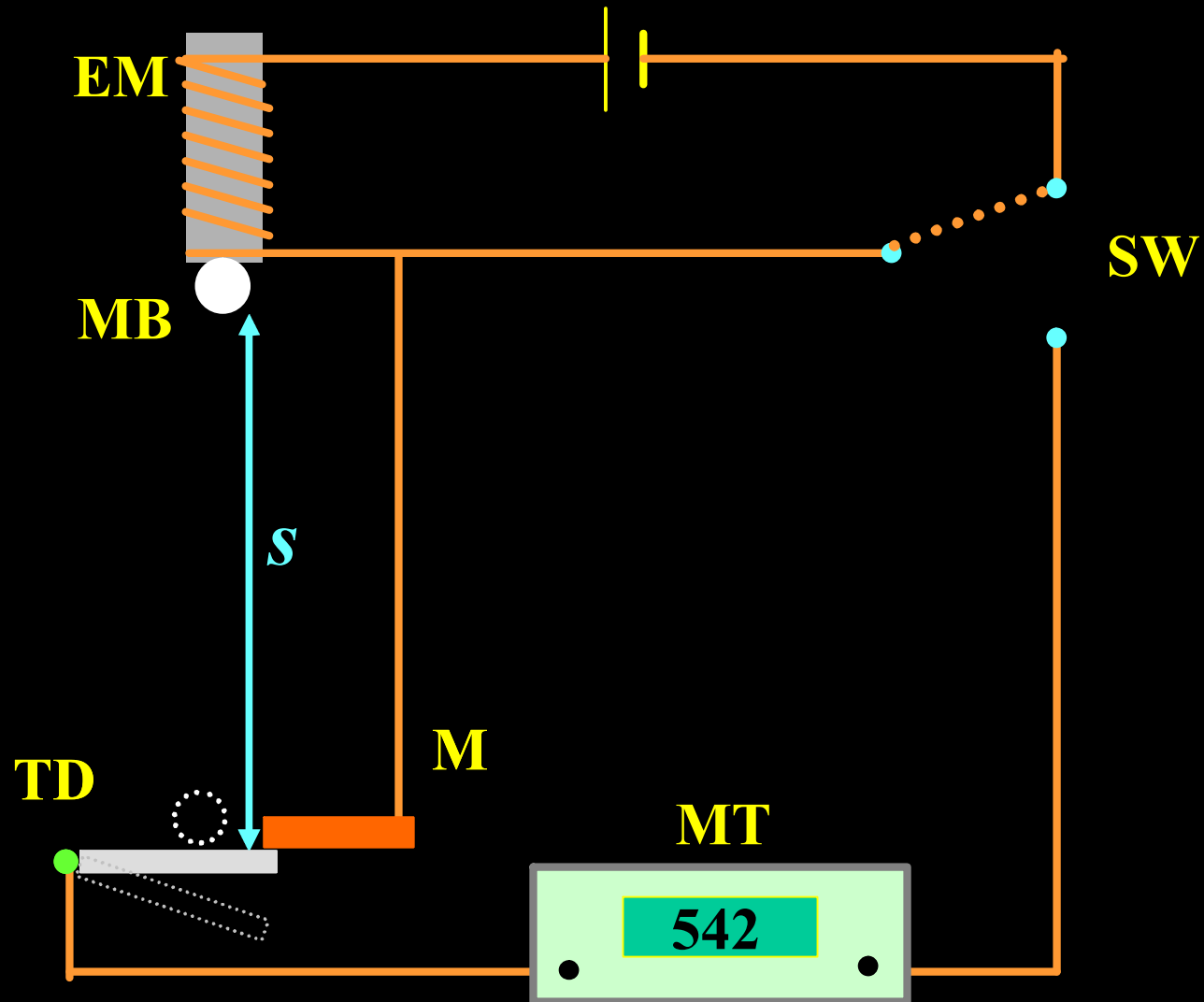

Expt. Measure g by Free-Fall

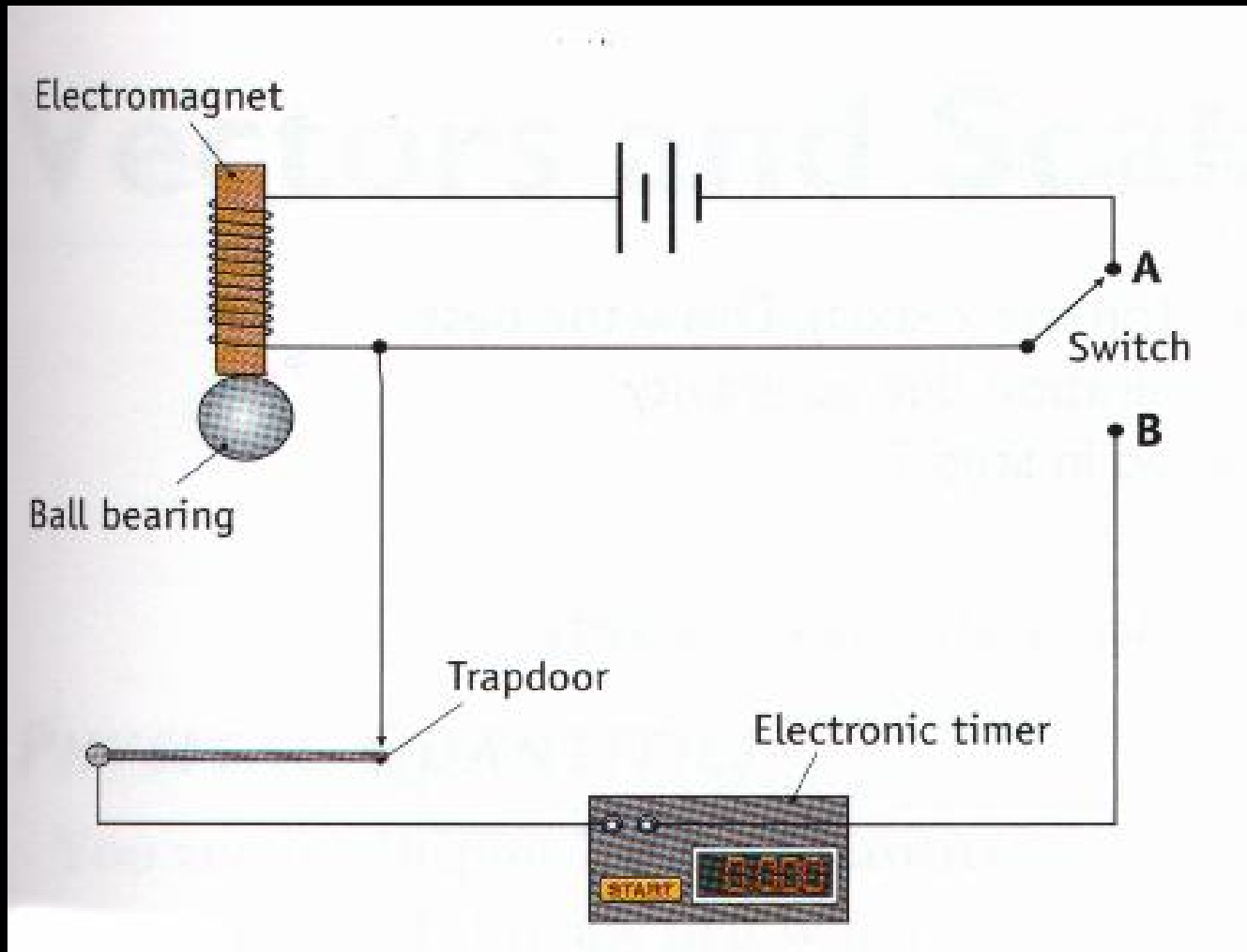

Procedure

(Expt. Measure g by Free-Fall)

1. Flick switch.
Ball falls freely.
Timer starts & stops auto ...
Repeat for same height.
2. Measure s , t .
3. s = distance from ... to ...
 t = smallest time ...
4. Repeat ... other heights ... to average g / to graph

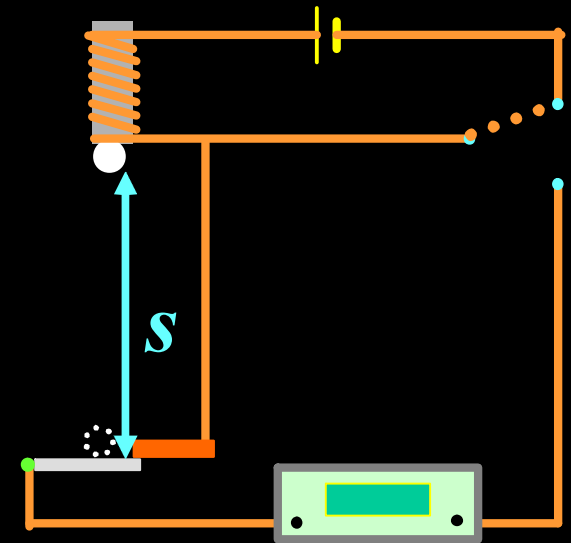

Results

(Expt. Measure g by Free-Fall)

Distance Fallen	Time For Fall in seconds	Smallest Time	Acceleration Due To Gravity
s / m	t ₁ , t ₂ , t ₃ , t ₄	t / s	g / m s ⁻²

$$s = u t + \frac{1}{2} a t^2$$

$$s = 0 + \frac{1}{2} g t^2$$

$$\Rightarrow g = \frac{2s}{t^2}$$

*Calculate
average g*

or ...



Results

(Expt. Measure g by Free-Fall)

$$s = u t + \frac{1}{2} a t^2$$

$$s = 0 + \frac{1}{2} g t^2$$

$$s = \left(\frac{1}{2} g\right) t^2$$

$$\begin{array}{ccc} | & | & | \end{array}$$

$$y = m x$$

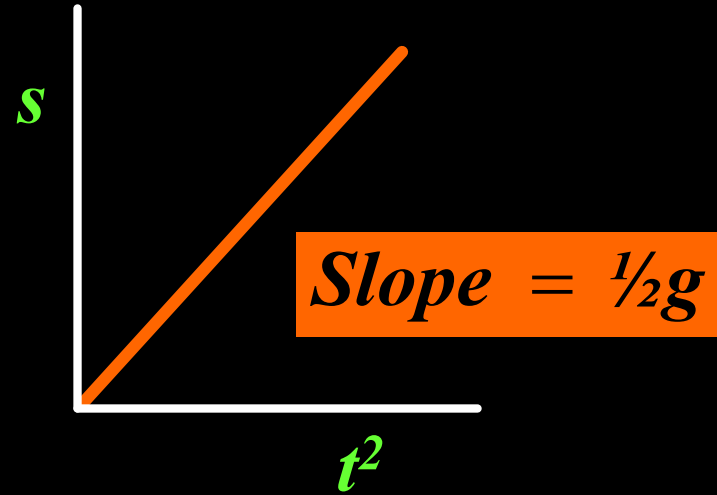

$$g = \text{slope} \times 2$$

Results

(Expt. Measure g by Free-Fall)

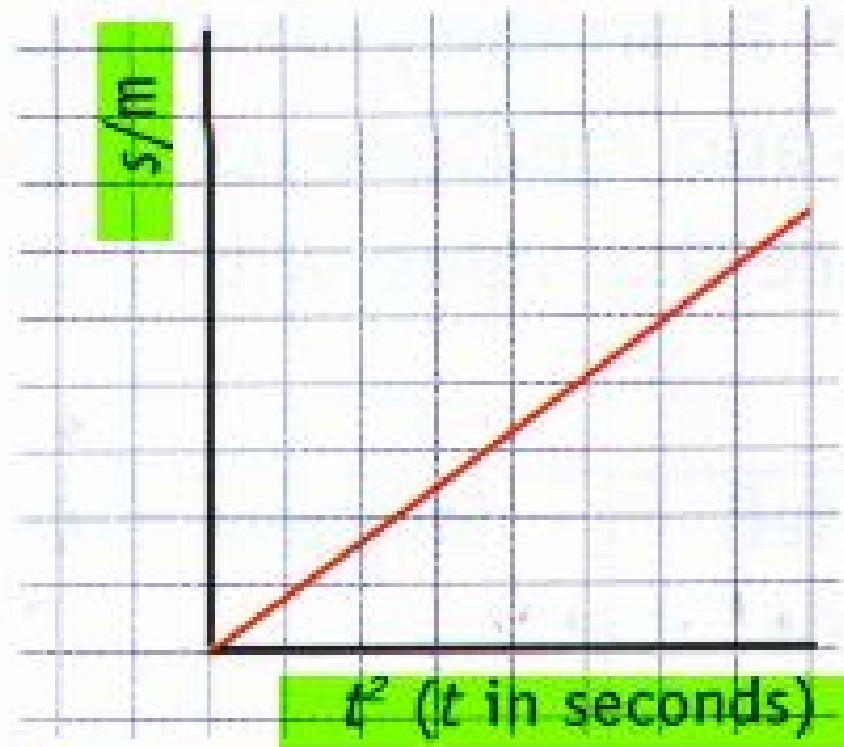

$$g = 2 \times \text{slope of graph}$$

Precautions

(Expt. Measure g by Free-Fall)

- Good release method (burn / paper / ruler ...)
- Smallest time
- Larger height
- Trapdoor loosely held
- Repeat to get average g